



# XMOS XVF3800 - User Guide

Release: 3.2.1

Publication Date: 2024/10/29

# Table of Contents

<b>1</b>	<b>Overview</b>	<b>1</b>
<b>2</b>	<b>Setting Up the Hardware</b>	<b>2</b>
2.1	Introduction	2
2.2	Hardware Setup - USB Accessory (UA) Configuration	2
2.2.1	UA - Required Components	2
2.2.2	Setting up the Evaluation System in UA Configuration	2
2.2.3	Installing the UA firmware	4
2.3	Hardware Setup - I <sup>2</sup> S (INT-Device) Configuration	5
2.3.1	INT-Device Required Components	5
2.3.2	Setting up the INT-Device configuration	6
2.3.3	Installing the INT-Device Firmware	7
2.4	Setting up the Audio	8
2.4.1	Loudspeaker	8
2.4.2	Playback and Recording	10
2.4.2.1	I <sup>2</sup> S Audio Configuration	10
2.4.2.2	UA Audio Configuration	10
2.5	Troubleshooting	11
2.5.1	Audio Signals	11
2.5.2	Low volume of recorded audio during audio playback	11
2.5.3	Low volume of playback audio on Linux for XVF3800-UA	11
2.5.4	AEC Convergence	12
<b>3</b>	<b>Using the Host Application</b>	<b>13</b>
3.1	Installing the Host Application	13
3.2	Instructions for Windows USB Driver Installation	14
3.3	Connecting to the XVF3800 Device	15
3.4	xvf_host Command Syntax	15
3.5	Microphone orientation	16
3.5.1	Beam forming subsystem and Direction of Arrival indicator	18
3.5.2	Using azimuth data For Direction of Arrival indication	20
3.6	Example Uses	20
3.6.1	Output Selection	21
3.6.2	Setting an Output Pin	23
<b>4</b>	<b>Tuning the Application</b>	<b>24</b>
4.1	System Preparation	24
4.1.1	Prerequisites	24
4.1.2	Initial Parameter Setting	26
4.1.3	Initial Tests	26
4.1.3.1	Input Path	26
4.1.3.2	Control Path	28
4.1.3.3	Output Path	28
4.1.3.4	Speaker Operation	28
4.1.3.5	Microphone Operation	29
4.2	Tuning the XVF3800 Parameters	29
4.2.1	Reference Gain	29
4.2.2	Microphone Gain	30
4.2.3	Silence level	30
4.2.4	System Delay	31
4.2.5	AEC Operation	33
4.2.6	AGC Configuration	35



4.2.7	Emphasis	36
4.2.8	MGSCALE	37
4.2.9	FMIN_SPEINDEX	37
4.2.10	Tuning the Non-Linear Model	39
4.2.10.1	Non-linear Echo	39
4.2.10.2	Tuning Setup for Non Linear model	40
4.2.11	Echo Suppression	44
4.2.11.1	PP_DTSENSITIVE	45
4.2.11.2	PP_GAMMA_E and PP_GAMMA_ENL	46
4.2.11.3	PP_GAMMA_ETAIL	46
4.2.12	Noise Suppression	47
4.2.13	ATTNS	47
4.2.13.1	ATTNS_NOMINAL	48
4.2.13.2	ATTNS_SLOPE	48
4.2.14	Path Change Detection	49
4.2.15	Output equalization	49
4.3	Changing Default Parameter Values	51
<b>5</b>	<b>Building the Application Firmware</b>	<b>55</b>
5.1	Introduction	55
5.2	Prerequisites	55
5.2.1	Python3	55
5.2.2	XMOS tools	55
5.2.3	Build Tools	56
5.3	XVF3800 Release Package	56
5.3.1	Standard Configurations	57
5.3.2	Image Names	57
5.4	Build Process	58
5.4.1	Set up the environment	58
5.4.2	Configure the build system	58
5.4.3	Build an executable	59
5.5	Installing the Executable Image	59
5.5.1	Install Using xrun	59
5.5.2	Install Using xflash	59
5.6	Using SPI Boot	60
5.6.1	Creating a SPI Boot File	60
5.6.2	Using a SPI Boot File	60
5.6.2.1	Safe SPI Booting	60
5.6.2.2	Fast SPI booting	61
<b>6</b>	<b>Some Acoustic Design Guidelines</b>	<b>63</b>
6.1	Microphones	63
6.2	Loudspeaker(s)	65
6.3	Enclosure and mounting	66
<b>7</b>	<b>DFU operations</b>	<b>67</b>
7.1	Setting up the host computer (UA)	67
7.2	Setting up the host computer (INT)	67
7.3	Generation of Binary Upgrade Image	68
7.4	Examples of DFU operations	69
7.4.1	Download an upgrade image to the device	69
7.4.2	Revert the device to factory image	70
7.4.3	Reboot the device	70
7.4.4	Upload the images from the device	70
7.4.4.1	Error handling	71
<b>8</b>	<b>Automatic speech recognition</b>	<b>72</b>
<b>9</b>	<b>HID Interface</b>	<b>73</b>

<b>10 APPENDIX – Control Commands</b>	<b>74</b>
10.1 AEC Tuning and Control Commands . . . . .	74
10.2 Device Metadata Commands . . . . .	79
10.3 Audio Manager Commands . . . . .	80
10.4 GPIO Commands . . . . .	83
<b>11 APPENDIX – Tuning the Loudspeaker</b>	<b>84</b>
11.1 Adding EQ to the Loudspeaker Frequency Response . . . . .	84
11.2 Setting the Maximum Loudspeaker Volume . . . . .	85
11.3 Remaining Steps . . . . .	85
<b>12 APPENDIX – Alternative Tuning Parameters</b>	<b>86</b>
12.1 Personal Space Speakerphone using a Logitech Z50 loudspeaker . . . . .	86
12.2 Shared Space Speakerphone at 4.5 m using a Genelec 8020 loudspeaker . . . . .	87
<b>13 APPENDIX – List of applications</b>	<b>88</b>
13.1 UA device applications . . . . .	88
13.2 INT device applications . . . . .	88

# 1 Overview

---

The XMOS VocalFusion ® XVF3800 is a high-performance voice processor that uses microphone array processing and a sophisticated audio processing pipeline to capture clear, high-quality speech from anywhere in a room. The XVF3800 uses the XMOS xcore.ai processor and supports a range of integrated and accessory voice communication applications.

The audio processing pipeline includes Philips BeClear SuperHandsFree (SHF) components.

This document discusses:

- Setting up the hardware,
- Using the Host application,
- Tuning the XVF3800 firmware,
- Building and deploying an XVF3800 executable image,
- Some acoustic design guidelines,
- Tools for device firmware upgrade (DFU),
- Configuring the firmware for operations with an Automatic Speech Recognition (ASR), and
- HID capability.

It also includes several useful appendices.

## 2 Setting Up the Hardware

---

### 2.1 Introduction

This section explains the process of setting up and configuring the XVF3800 firmware on an XK-VOICE-SQ66 development kit.

Version v3.2.1 of the XVF3800 firmware supports audio I/O via I<sup>2</sup>S or USB UAC2. The instructions below describe how to set up an evaluation system in either configuration.

---

**Note:** The XK-VOICE-SQ66 development kit is intended for use as an evaluation board for the XVF3800 and after power on or reset the device will stop processing audio after 8 hours of continuous use. The board must be restarted after 8 hours to resume operation. Licensed production XVF3800 devices do not have this restriction.

---

### 2.2 Hardware Setup - USB Accessory (UA) Configuration

The UA configuration is the simplest configuration as the XK-VOICE-SQ66 development kit can be connected directly to a computer using a USB port.

#### 2.2.1 UA - Required Components

- An XK-VOICE-SQ66 development kit board.
- An XMOS XTAG4 with associated ribbon cables (Provided in the XK-VOICE-SQ66 development kit package).
- A setup computer and a development computer (Windows, macOS or Linux are supported). Each computer must have at least one USB connection. A single computer with at least two USB connections may be used to fulfil both roles.
- A micro USB cable to connect the setup computer to the XTAG4 and a second micro USB cable to connect the XK-VOICE-SQ66 development kit to the development computer.

#### 2.2.2 Setting up the Evaluation System in UA Configuration

The following steps are required to set up the XVF3800 evaluation hardware:

1. On the development computer, install the latest available *XTC Tools*, available from <https://www.xmos.com/software-tools/>. Installation instructions for the supported platforms are available at <https://www.xmos.com/view/Tools-15-Documentation>.
2. Connect the USB port on the XK-VOICE-SQ66 development kit to the development computer using a USB cable. (This provides power to the device.)
3. Connect an XTAG-4 debug adapter to the setup computer via USB, and connect it to the XK-VOICE-SQ66 development kit using the supplied ribbon cable. The cable should be plugged into XSYS2 connector on the XK-VOICE-SQ66 development kit. [Fig. 2.1](#) shows the UA configuration of the XK-VOICE-SQ66 development kit.



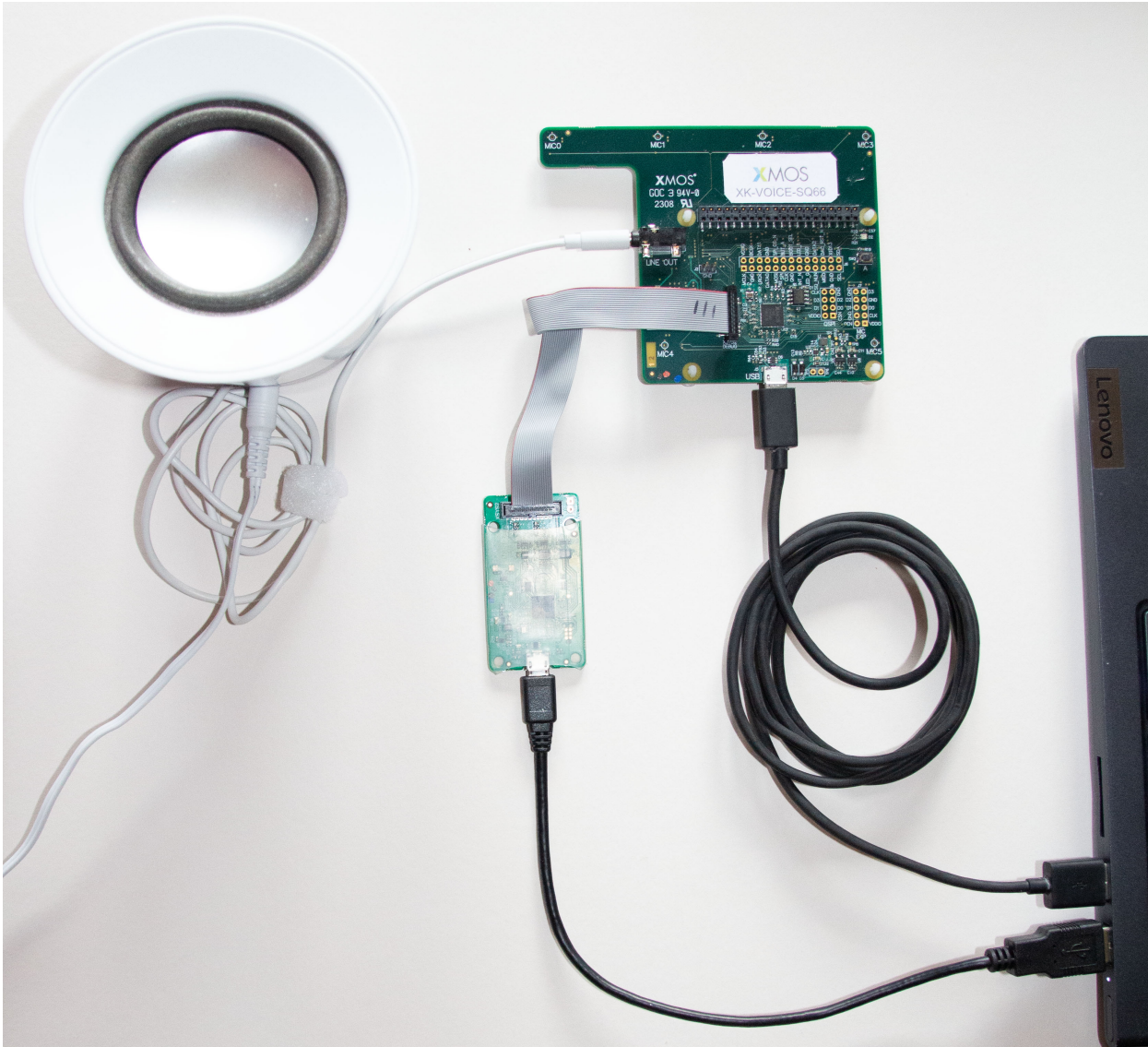

Fig. 2.1: XK-VOICE-SQ66 development kit in UA configuration

1. Open an XTC tools terminal window on the development computer. Verify that the XTAG4 has been correctly connected by running the following command in that window:

```
xflash -l
```

The output from this should be of the following form:

```
Available XMOS Devices
-----
  ID   Name           Adapter ID  Devices
  --   ---           -
  0    XMOS XTAG-4     ABCDE123  P[0]
```

**Note:** If the XTAG-4 is not properly connected to the development computer, then `xflash` will report `No Available Devices Found`. If the XK-VOICE-SQ66 development kit is not properly connected to the XTAG-4, then the `Devices` column will read `None`. For further guidance on the use of the *XTC tools*, see the <https://>

## 2.2.3 Installing the UA firmware

The XVF3800 binary release package provided contains several precompiled binaries.

The provided binary images have names in the format:

`application_xvf3800_ua[configuration-options].xe`

where the [configuration-options] is constructed as detailed in [Table 2.1](#).

Table 2.1: Build configuration settings for UA

Option	Values	Description
USB sample rate	-io16 / -io48	to choose between a 16 kHz or 48 kHz rate for the USB rate. Input and output rates must be the same. This setting is only used in UA configurations
Microphone topology	-sqr / -lin	to choose between a “squarecircular” or linear microphone array
Audio output	-spatial	to choose between a stereo output from the device giving audible indication of the location of the speaker, or the default output
I <sup>2</sup> C-to-IO expander	-io-exp	to choose between using the I <sup>2</sup> C-to-IO expander connected to the XK-VOICE-SQ66 development kit, or not

Select the required binary firmware image from the release package, and transfer it to the XK-VOICE-SQ66 development kit using the `xflash` tool.

```
xflash application_xvf3800_ua[...].xe
```

The XTAG4 adapter can be disconnected from the XK-VOICE-SQ66 development kit after successfully installing the firmware image if desired.

After completing the initial setup, follow the instructions in the section [Setting up the Audio](#) below.



---

## 2.3 Hardware Setup - I<sup>2</sup>S (INT-Device) Configuration

The following instructions explain how to set up a Raspberry Pi computer with the XK-VOICE-SQ66 development kit in order to evaluate the operation of the XVF3800 using an I<sup>2</sup>S audio interface in the INT-Device configuration.

### 2.3.1 INT-Device Required Components

- An XK-VOICE-SQ66 development kit board.
- An XMOS XTAG4 with associated ribbon cables (Provided in the XK-VOICE-SQ66 development kit package).
- A setup computer (Windows, macOS or Linux are supported). This computer must support USB connections and have the ability to write onto SD memory cards.
- A USB cable to connect the setup computer to the XTAG4.
- A Raspberry Pi microcomputer; either a Raspberry Pi 3 Model B or 4 Model B will work for this evaluation. See <https://www.raspberrypi.com/> for more information.
- A region-appropriate USB power supply is also required. The XK-VOICE-SQ66 development kit obtains its power supply from the Raspberry Pi.
- An SD memory card - minimum 8GB size
- A stacking header block, as pictured in Fig. 2.2 to mount the XK-VOICE-SQ66 development kit board onto the Raspberry Pi using the standard 40 pin GPIO header. For your convenience a suitable header block is included in the XK-VOICE-SQ66 development kit package.

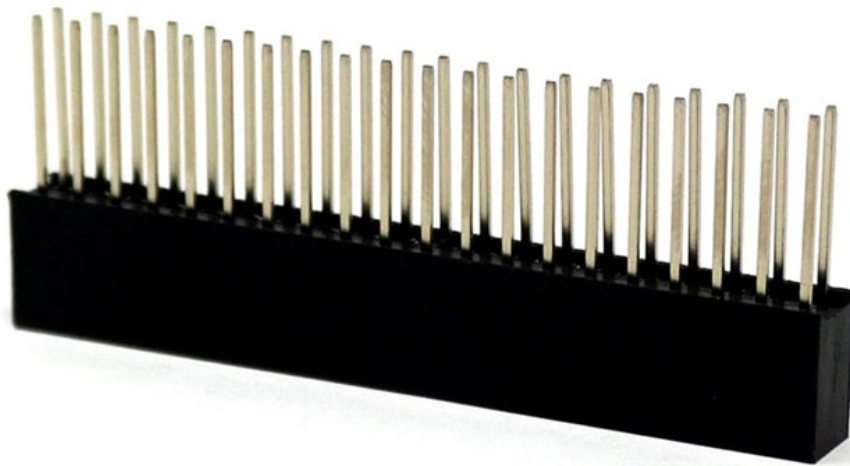

Fig. 2.2: Raspberry Pi HAT Connector - 10 mm Extended Tail Socket

- The XVF3800 evaluation firmware binary release package (available from the XVF3800 [developer page](#)).

## 2.3.2 Setting up the INT-Device configuration

The following steps are required to set up the XVF3800 evaluation hardware:

1. On the setup computer, install the latest available *XTC Tools*, available from <https://www.xmos.com/software-tools/>. Installation instructions for the supported platforms are available at <https://www.xmos.com/view/Tools-15-Documentation>.
2. Instructions and a script for setting up the Raspberry Pi are provided at <https://github.com/xmos/vocalfusion-rpi-setup>. Follow these instructions to generate the OS image and configure the Raspberry Pi.
3. When running the setup script on the Raspberry Pi, the following commands should be used to setup the Raspberry Pi for use with the XK-VOICE-SQ66 development kit:

```
git clone https://github.com/xmos/vocalfusion-rpi-setup
cd vocalfusion-rpi-setup
./setup.sh xvf3800-intdev
```

1. To enable a remote GUI access on the Raspberry Pi, the VNC service should be enabled at this point with the following command.

```
sudo raspi-config
```

Select 3 Interfaces Options and enable VNC and SSH (if not already set using the imager) on the next screen.

2. Shutdown the Pi, detach the power and mount the XK-VOICE-SQ66 development kit board onto the Raspberry Pi header. After mounting the board, reattach power and verify the Raspberry Pi restarts.
3. The evaluation hardware should be placed on a piece of foam. This is to prevent the loudspeaker causing the board to vibrate and buzz on the table, causing the acoustic coupling between them to vary. In a final product, the loudspeaker and microphone will be build into to the same housing, and so the coupling cannot vary.

The evaluation hardware is now ready to use, and should resemble [Fig. 2.3](#).

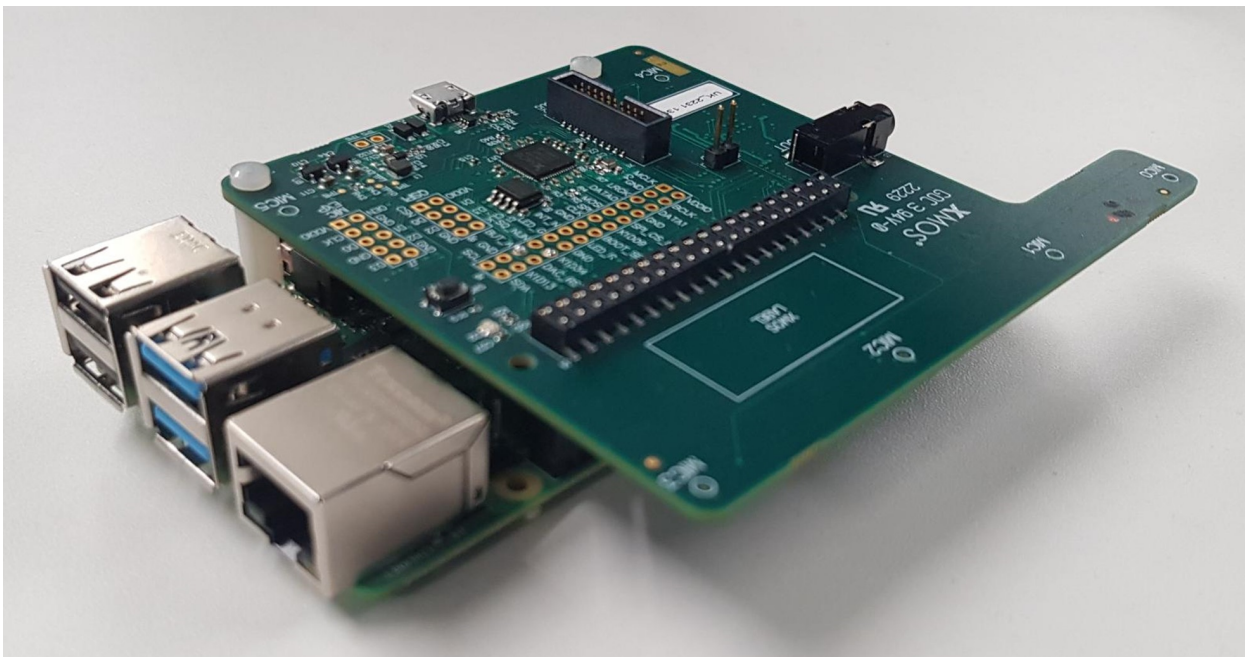

Fig. 2.3: XVF3800 evaluation kit

### 2.3.3 Installing the INT-Device Firmware

The XVF3800 binary release package provided contains several precompiled binaries.

The provided binary images have names in the format:

```
application_xvf3800_intdev[configuration-options].xe
```

where the [configuration-options] is constructed as detailed in [Table 2.2](#).

Table 2.2: Build configuration settings for INT

Option	Values	Description
I2S Sample rate	-lr16 / -lr48	to choose between a 16 kHz or 48 kHz I <sup>2</sup> S LR clock (and therefore reference input and processed output audio sample rate). This setting is only used in INT configurations
Microphone topology	-sqr / -lin	to choose between a “squarecircular” or linear microphone array
Control protocol	-i2c / -spi	to choose between I <sup>2</sup> C and SPI control modes. This setting is only used in INT configurations, the UA configurations always use USB control mode
Audio MCLK	-extmclk	to choose between external or internal MCLK. This setting is only used in INT configurations
Audio output	-spatial	to choose between a stereo output from the device giving audible indication of the location of the speaker, or the default output

**Note:** Some binaries are provided which have the suffix `-extmclk`. These are intended for use in systems where an external MCLK is provided, and they disable the XVF3800’s clock recovery system. These builds are not for use with a Raspberry Pi.

The firmware is installed using the XMOS XTAG4 adapter supplied with the XK-VOICE-SQ66 development kit.

1. Connect an XTAG-4 debug adapter to the setup computer via USB, and connect it to the XK-VOICE-SQ66 development kit using the supplied ribbon cable. The cable should be plugged into XSYS2 connector on the XK-VOICE-SQ66 development kit.
2. Open an XTC tools terminal window on the computer. Verify that the XTAG4 has been correctly connected by running the following command in that window:

```
xflash -l
```

The output from this should be of the following form:

```
Available XMOS Devices
-----
ID      Name           Adapter ID  Devices
--      -
0       XMOS XTAG-4    ABCDE123   P[0]
```

**Note:** If the XTAG-4 is not properly connected to the development computer, then `xflash` will report `No Available Devices Found`. If the XK-VOICE-SQ66 development kit is not properly connected to the XTAG-4, then the `Devices` column will read `None`. For further guidance on the use of the *XTC tools*, see the <https://www.xmos.com/view/Tools-15-Documentation>.

- 
3. Select the required binary firmware image from the release package, and transfer it to the XK-VOICE-SQ66 development kit using the xflash tool.

```
xflash application_xvf3800_intdev[...].xe
```

The XTAG4 adapter can be disconnected from the XK-VOICE-SQ66 development kit after successfully installing the firmware image if desired.

After completing the setup, follow the instructions below to set up the audio path.

## 2.4 Setting up the Audio

### 2.4.1 Loudspeaker

To play reference audio into the room, a high quality loudspeaker operating in its linear region is required.

Connect the loudspeaker to the LINE OUT port on the XK-VOICE-SQ66 development kit, which accepts a 3.5 mm TRS jack plug connector. The left channel of the LINE OUT port must be used for the speaker signal.

It is important for the ideal demonstration that the position, orientation, and volume of the loudspeaker are representative of a real-world system.

To achieve optimal performance:

- Align the front of the loudspeaker with the microphone strip at the top of the XK-VOICE-SQ66 development kit and
- Place the loudspeaker 2-4 cm away from the device

An example layout can be seen pictured in [Fig. 2.4](#).



Fig. 2.4: XVF3800 demo example layout

---

**Note:** The XVF3800 implements a mono audio processing pipeline so a mono speaker system should be used for optimum performance. By default the system uses the left channel (channel 0 on I2S) as the AEC reference signal. If stereo speakers are used, both speakers will play the left channel.

---

To calibrate the volume of the loudspeaker for optimal performance, a test file such as the [IEEE 269-2010 Male Mono 48 kHz signal](#) can be used.

These test signals can be downloaded from:

```
https://standards.ieee.org/wp-content/uploads/import/download/269-2010_downloads.zip
```

and stored on the computer used for playback (USB host or I<sup>2</sup>S host). If the Raspberry Pi is connected to the internet the files can be copied with the following:

```
curl --output <FILE>.zip https://standards.ieee.org/wp-content/uploads/import/download/269-2010_
↳downloads.zip
unzip <FILE>.zip
```

The output volume must be changed directly on the loudspeaker or on a connected amplifier, not on the computer. In this example, the volume of the track measured at a 1 metre distance from the loudspeaker should be  $73 \text{ dB}_A \pm 2 \text{ dB}_A$  on average, but for tuning the device against a specific set of requirements ensure that the relevant output level has been achieved for the targetted specification. Ensure that the reference signal is not digitally clipped as it is sent to the device; this can lead to non-obvious issues in device performance.

---

## 2.4.2 Playback and Recording

### 2.4.2.1 I<sup>2</sup>S Audio Configuration

Playback and recording through the XVF3800's I<sup>2</sup>S interface, once the Raspberry Pi has been set up correctly, can be achieved through standard use of the ALSA card `snd_rpi_simple_card`, device `0`. For example, from the command line, a 2 channel 32-bit 48 kHz WAV file may be played as reference audio through `aplay` with the following command:

```
aplay -c 2 -f S32_LE -r 48000 -D hw:sndrpisimplecar,0 <filename>
```

Similarly, `<time>` seconds of processed audio from the XVF3800 may be recorded to a file with:

```
arecord --mmap -c 2 -d <time> -f S32_LE -r 48000 -D hw:sndrpisimplecar,0 <filename>
```

Alternatively, in a desktop environment on the Raspberry Pi, Audacity™ may be used to visually play and record. The sample rate must be set to match the XVF3800 in the *Project Rate (Hz)* selection in the bottom left, or in the *Edit -> Preferences -> Audio Settings* menu.

The sound card settings must match the ones highlighted in [Fig. 2.5](#):

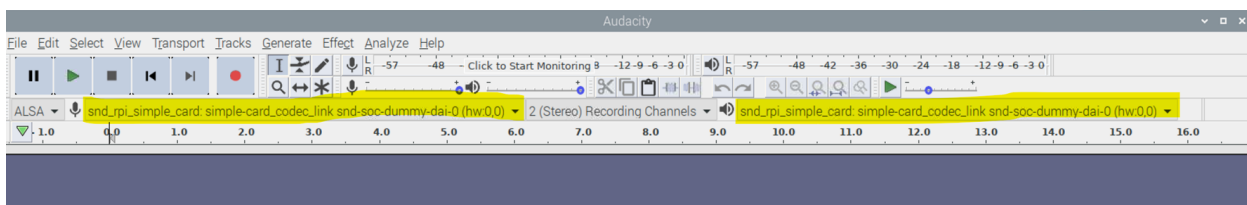

Fig. 2.5: Audacity™ example

### 2.4.2.2 UA Audio Configuration

In the UA configuration, Audacity™ may be used to visually play and record signals from the device. The sample rate must be set to match the XVF3800 in the *Project Rate (Hz)* selection in the bottom left, or in the *Edit -> Preferences -> Audio Settings* menu.

The device should appear as a USB sound card with the default name of `XMOS XVF3800 Voice Processor`. On Audacity both playback and recording devices should be set to be the XVF3800.

With the standard evaluation firmware the USB parameters are:

```
Product_STR: XMOS XVF3800 Voice Processor
Manufacturer_STR: XMOS
Vendor_ID (VID): 0x20b1
Product_ID (PID): 0x4f00 (48 kHz sample rate) or 0x4f01 (16 kHz sample rate)
Serial Number: 00000000
```

These can be modified, along with other USB parameters - see the subsection about [Changing Default Parameter Values](#), for details.

---

**Note:** In the default configuration the USB Audio bit-depth is set at 16bit. The XVF3800 also supports a bit depth of 24bit or 32bit over USB. This can be changed using the control command `USB_BIT_DEPTH` or modifying the usb default parameters (see `sources/app_xvf3800/cmd_map_gen/yaml_files/defaults/usb_param_values.yaml` in the release package)

---



---

## 2.5 Troubleshooting

### 2.5.1 Audio Signals

If audio is being played by the host but not heard from the loudspeaker, it is likely that there exists a connection issue between the host and the XK-VOICE-SQ66 development kit board. Ensure that the XK-VOICE-SQ66 development kit board is powered, and the loudspeaker connected and powered. The right channel of the far end is not played out of the DAC so ensure your audio source contains a signal in the left channel.

If audio is heard from the loudspeaker but no input audio is received by the host, ensure that the host is configured to transmit and receive audio at the correct sample rate (either 16 kHz or 48 kHz, depending on the chosen firmware).

On Windows, the USB audio drivers are cached, and this can cause issues if an out-of-date audio driver has been installed. In this case, it is recommended to clear the cached audio drivers using the third-party tool *USBDeview*. The executable can be downloaded from [https://www.nirsoft.net/utils/usb\\_devices\\_view.html](https://www.nirsoft.net/utils/usb_devices_view.html), and the cached drivers can be removed by using the *USBDeview* GUI, or by typing from a command line with Administrator rights one or both of the lines below:

```
USBDeview.exe /RunAsAdmin /remove_by_pid 20b1;4f00 &REM 48 kHz sample rate
USBDeview.exe /RunAsAdmin /remove_by_pid 20b1;4f01 &REM 16 kHz sample rate
```

If there is still no input from the device, it is possible that the device firmware has stalled; disconnect and reconnect power to the XK-VOICE-SQ66 development kit to reset the device, and then attempt input again.

### 2.5.2 Low volume of recorded audio during audio playback

When playing audio through the loudspeaker, it is important that in the test track chosen, near-end speech doesn't overlap extensively with the far-end audio. If this happens, the near-end audio will be suppressed; this is a common feature of a conference audio device. In the *Loudspeaker* section some audio tracks are recommended for testing. These tracks contain audio interspersed with silence, so that the near-end speaker can talk while the far-end audio is silent.

If the instructions above are followed, the Automatic Gain Control (AGC) of the device will lower and increase the near-end speech accordingly. If the volume of the recorded near-end audio is still too low, please follow the steps in the *AGC Configuration* section to properly tune the AGC.

### 2.5.3 Low volume of playback audio on Linux for XVF3800-UA

If the volume of the loudspeaker output of the XVF3800-UA on Linux is too low, it is possible that the `alsamixer` levels of the XVF3800 soundcard must be updated. To do this, follow the steps below:

1. Open a terminal and type `alsamixer`.
2. Press `F6` to open the soundcard menu.
3. Use the up-down arrows to select the XVF3800 sound card and press `Enter`
4. In the menu below, the `PCM-1` volume could be 40 (-20 dB) instead of 100,



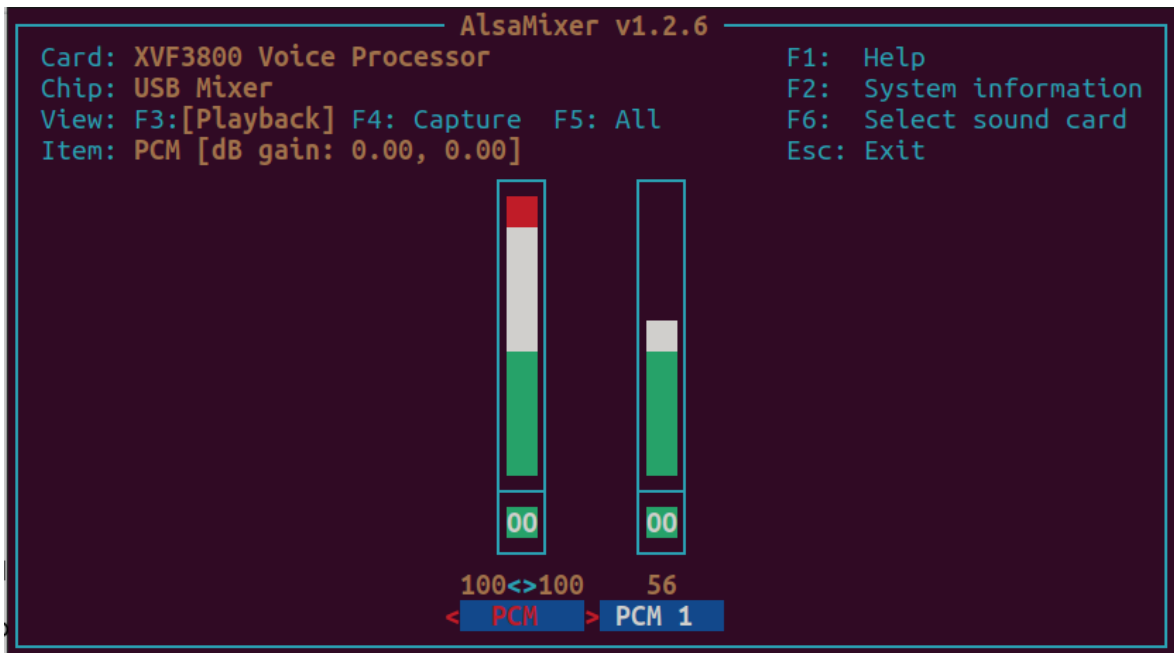

use the keyboard arrows to select *PCM-1* volume and increase it up to 100%.

5. Press *ESC* to exit *alsamixer*.
6. Before unplugging the XVF3800-UA, run the command:

```
sudo alsactl store
```

to store the setting permanently; otherwise the steps above must be repeated every time the XVF3800-UA is re-connected.

## 2.5.4 AEC Convergence

The AEC requires a reference signal be present in order to converge on a room transfer function estimate - this process will take a few seconds after reference audio has begun being provided. If the AEC has not been allowed to converge, the XVF3800 will tend to over-suppress near-end speech in its output to avoid undesirable artefacts being relayed to the far-end. This effect does subside within the first few seconds of use, so if the device is unexpectedly restarted then performance will be reduced momentarily but should restore over time.

If the device has consistently poor acoustic performance, it is likely that the AEC has not converged appropriately; restart the device and repeat the AEC convergence procedure described in the later sections to reset the AEC to a new set of coefficients.

If this does not resolve the issues, it is permissible to lower the loudspeaker volume. If loudspeaker volume is adjusted, or if there is any other change in environment, ensure that the AEC has reconverged before proceeding by playing several seconds of far-end audio again. The AEC will constantly reconverge, so a small change in environment such as a window opening or a change in loudspeaker volume should be automatically adjusted for by the AEC; however, actions that alter the direct delay path significantly, such as moving the loudspeaker, will require the device be reset and the AEC be allowed a few seconds to reconverge from startup.

## 3 Using the Host Application

---

The XVF3800 contains a control interface that enables users to configure the operation of the device and to set and read parameter data.

In v3.2.1, a sample host application, `xvf_host` (Linux, macOS, Raspberry Pi OS) or `xvf_host.exe` (Windows), is provided which can be used to connect to the control interface on the XVF3800. Please contact XMOS for information on using these tools on other host platforms.

Before using the host application, the host and hardware must be configured as described in [Setting up the hardware](#).

### 3.1 Installing the Host Application

The sample `xvf_host` application can be found in the binary release package in the subdirectory `host_v<version>/<platform>`. The supported platforms are `linux_x86_64`, `mac_x86_64`, `mac_arm64`, `rpi` and `win32`. This whole directory needs to be transferred to the host computer. It can be placed in any convenient location. This directory should contain the following files:

```
.
(lib)command_map.(so/dll/dylib) # All platforms
libdevice_i2c.so                # RPi only
libdevice_spi.so               # RPi only
dfu_cmds.yaml                  # RPi only
transport_config.yaml          # RPi only
(lib)device_usb.(so/dll/dylib) # All platforms
libusb-1.0.0.dylib             # Mac_x86_64 and Mac_arm64 only
xvf_dfu                         # RPi only
xvf_host(.exe)                  # All platforms
```

To verify the `xvf_host` application is installed, change to the directory and run the application as per the examples below, on Windows:

```
xvf_host.exe --help
```

on Linux, macOS and Raspberry Pi OS, the appropriate permissions must be set first:

```
sudo chmod +x xvf_host
sudo ./xvf_host --help
```

Users may find it convenient to store the host tools in a directory such as `~/bin` and add this to the `PATH` environment variable so that the tools can be invoked from any directory. This can be done on Windows with the “Edit system environment variables” GUI, or on the other platforms with the shell command:

```
PATH=~/bin:$PATH
```

---

**Note:** In the rest of this document when using the `xvf_host` app in the code examples, the command is written as `(sudo) xvf_host(.exe)`. The `.exe` extension is only required on Windows. The `sudo` command is only required on Linux, macOS and Raspberry Pi OS if the user does not have the necessary permissions to access the device. On these platforms it may be necessary to use `./` before the command if the directory containing the `xvf_host` app is not in the `PATH`.

---

## 3.2 Instructions for Windows USB Driver Installation

When connecting an XVF3800 device to a Windows host, the Control and DFU interfaces should be listed under the *Universal Serial Bus devices* section in the *Device Manager*, as shown below:

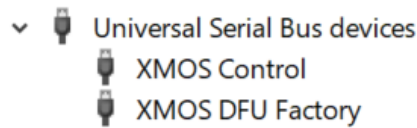

Fig. 3.1: USB interfaces in Device Manager on Windows

If this is not the case, it may be necessary to uninstall the existing drivers. This can be done by following the steps below:

1. open the *Device Manager* on Windows
2. find the device, which may be located under *libusb-win32 devices*
3. right-click on the device
4. select *Uninstall device*
5. check the box to delete the driver software for this device
6. click *Uninstall*

**Note:** If the interface continues to appear in its original location, it may be necessary to perform these steps multiple times, suggesting that the drivers have been installed on multiple occasions.

See the picture below for an example when *XMOS Control (Interface 3)* is listed under *libusb-win32 Devices*:

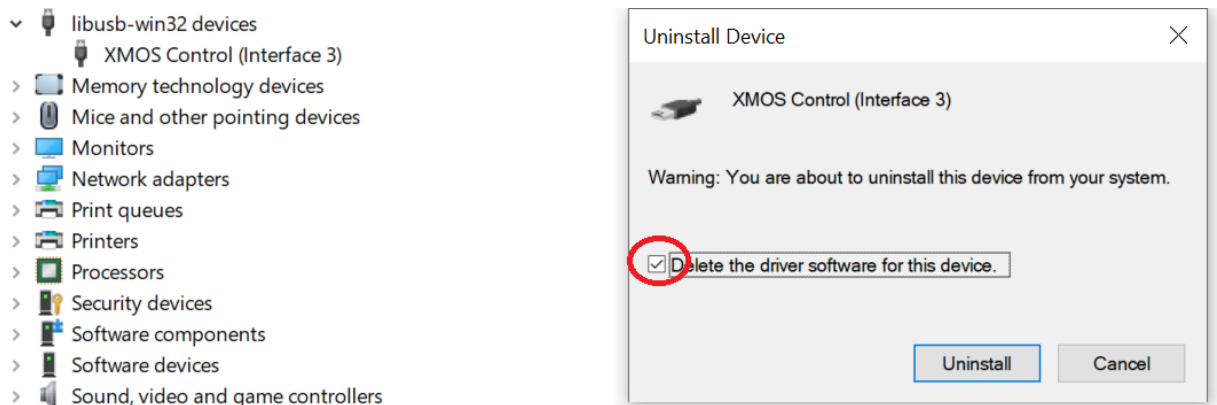

Fig. 3.2: Uninstalling the driver in Device Manager on Windows

---

## 3.3 Connecting to the XVF3800 Device

To use the host application, login to the host computer – either directly, via a VNC connection, or by `ssh` – to open a terminal command line.

Change to the directory containing `xvf_host(.exe)`. If the host tools have been added to the path as above this step is not needed.

The `xvf_host` device control application is run from the command line.

To check connection to the XVF3800, any command can be given; for example, the command

```
(sudo) xvf_host(.exe) --use <protocol> VERSION
```

where `<protocol>` can be `i2c`, `spi` or `usb` depending on the interface used in the specific firmware. The default control protocol is USB.

This command should return “3 2 1”.

---

**Note:** The host application has no mechanism to select between multiple VocalFusion/XVF devices. Using it with more than one XVF3800 device or with different VocalFusion/XVF devices connected at the same time may result in undefined behaviour.

---

## 3.4 xvf\_host Command Syntax

The general syntax of the `xvf_host` command is:

```
(sudo) xvf_host(.exe) [ command | option ]  
          [ -u <protocol> ] [ -cmp <path> ] [ -br ] [ command | option ]
```

More documentation on the available options in the use of the host application are found with:

```
(sudo) xvf_host(.exe) --help
```

A full list of control commands may be found using:

```
(sudo) xvf_host(.exe) --list-commands
```

These commands are also listed in [Control Commands Appendix](#).

It is possible to read all the control parameter settings from the XVF3800 using the following option:

```
(sudo) xvf_host(.exe) --dump-params
```

To support scripted set up of the XVF3800, it is possible to save the list of commands in a text file (.txt) which can be executed using:

```
(sudo) xvf_host(.exe) --execute-command-list <command_file>.txt
```

Further options for saving and loading parameter sets can found by using the `--help` option or in the section of the [Tuning the Application section](#).

### 3.5 Microphone orientation

The XVF3800 supports arbitrary microphone geometries which can be specified in configuration files. Two default configurations are included in the binary release package that are aligned to the geometries supported on the XK-VOICE-SQ66 development kit.

- The linear configuration (-lin) comprises 4 microphones in a linear array, spaced 33mm apart, as shown below:

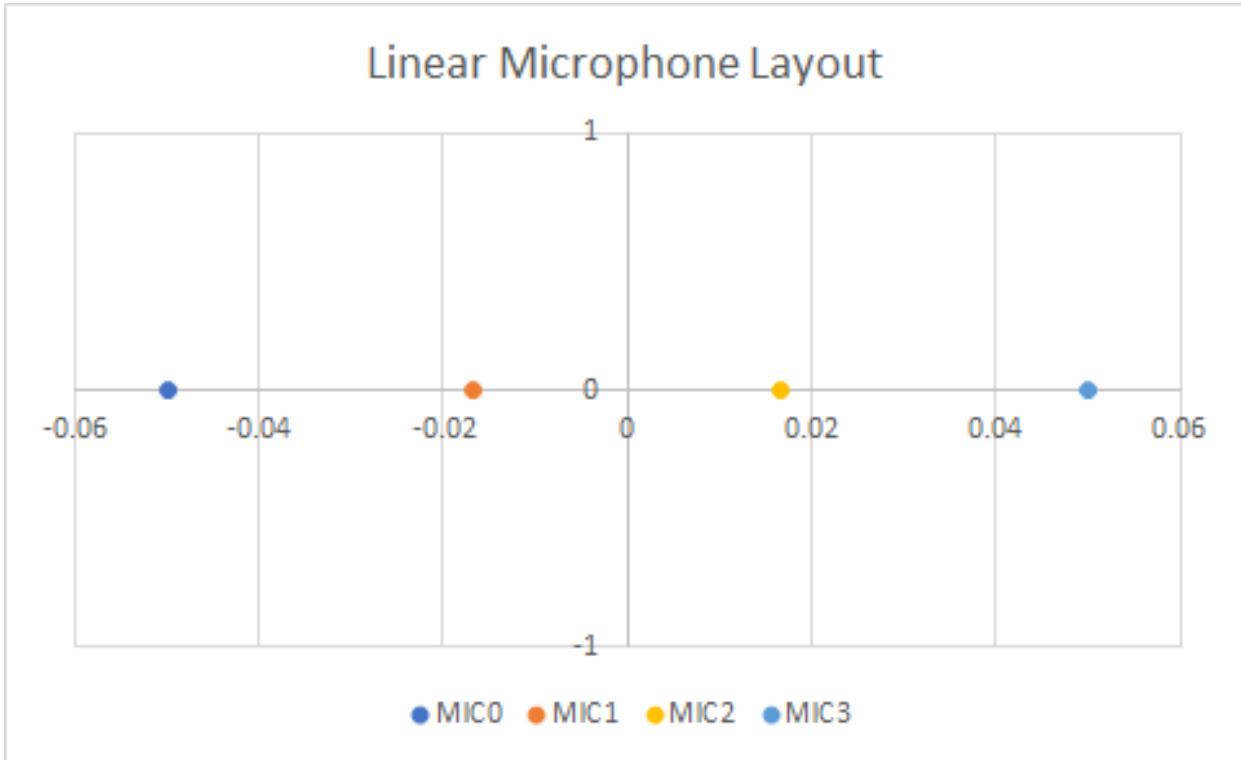

- The square configuration (-sqr) uses a 4 microphone array with a 66mm distance along each side as shown below.

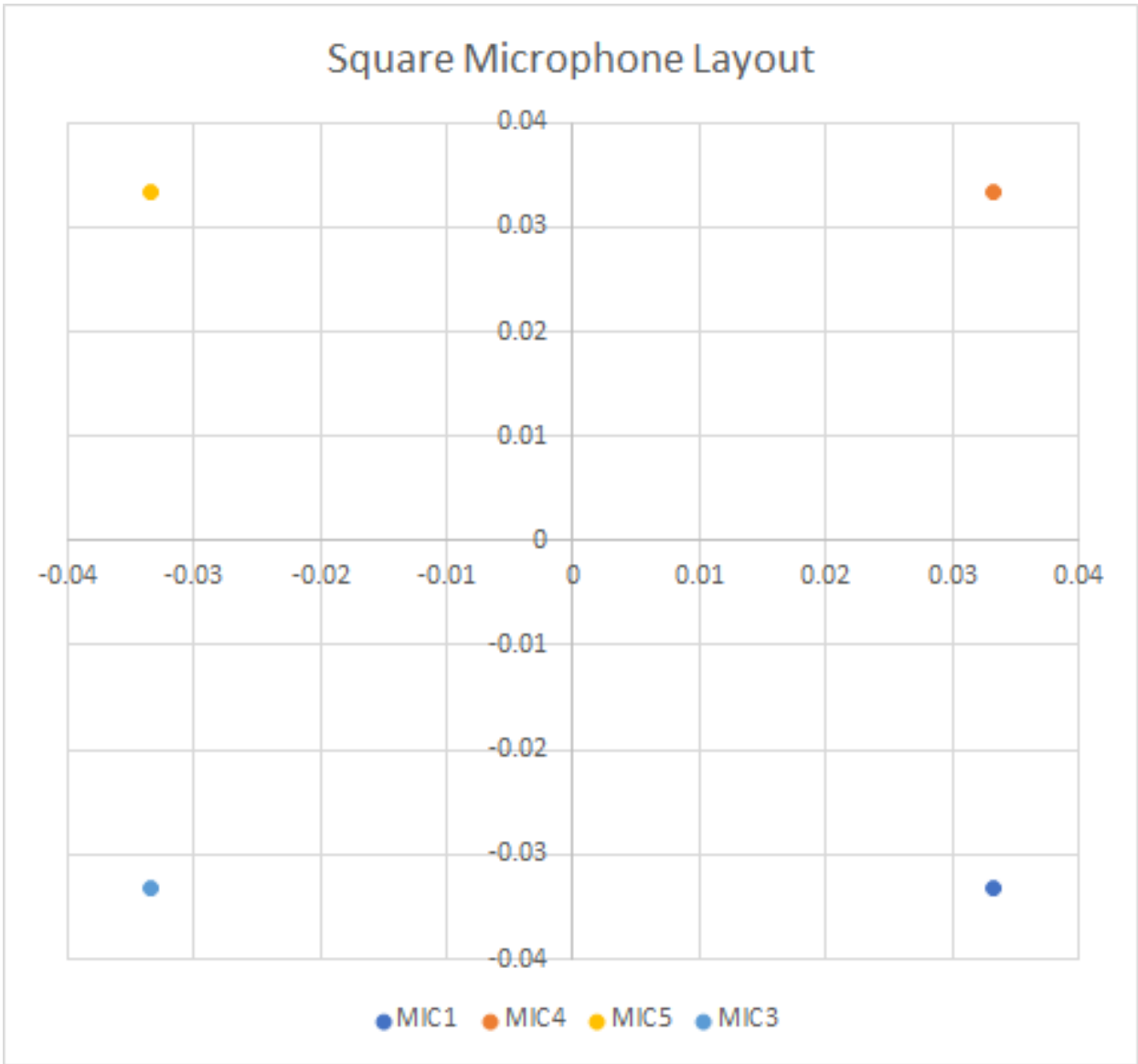

**Note:** These configurations are selected by a multiplexer on the XK-VOICE-SQ66 development kit when the device boots. They have to be configured as part of the firmware build and cannot be changed in operation.

The microphone numbers in the diagrams above correspond to the labels on the XK-VOICE-SQ66 development kit board. In the firmware configuration these microphones are mapped to 4 microphone indexes: MIC[0..3] which are used in the firmware and when using `xvf_host`. The mapping of the logical indexes and the physical microphones on the XK-VOICE-SQ66 development kit is shown in the table below:

Table 3.1: Microphone logical to physical mapping

Logical	Physical Microphone	
Microphone Index	Linear Config	Square Config
MIC0	MIC0	MIC1
MIC1	MIC1	MIC4
MIC2	MIC2	MIC5
MIC3	MIC3	MIC3



### 3.5.1 Beam forming subsystem and Direction of Arrival indicator

As described in XVF3800 datasheet, the system uses a set of beams to focus on speakers and reduce unwanted sounds and reverberation in the output signal. The XVF3800 uses a free running beam that scans the environment, identifies likely speakers and switches one of the two focused beams to that direction.

In normal operation the audio pipeline automatically selects the best signal to output.

It is possible to read back the direction that the beams are currently pointing. This is done with the `xvf_host` command `AEC_AZIMUTH_VALUES`. The output of the command contains 4 values:

- Focused beam 1
- Focused beam 2
- Free running beam
- Auto selected beam

Each value is the azimuth angle of the corresponding beam, provided in both radians and degrees. The coordinate system used depends on the hardware configuration. The diagrams below show the azimuth angles relative to the XK-VOICE-SQ66 development kit in the two default configurations.

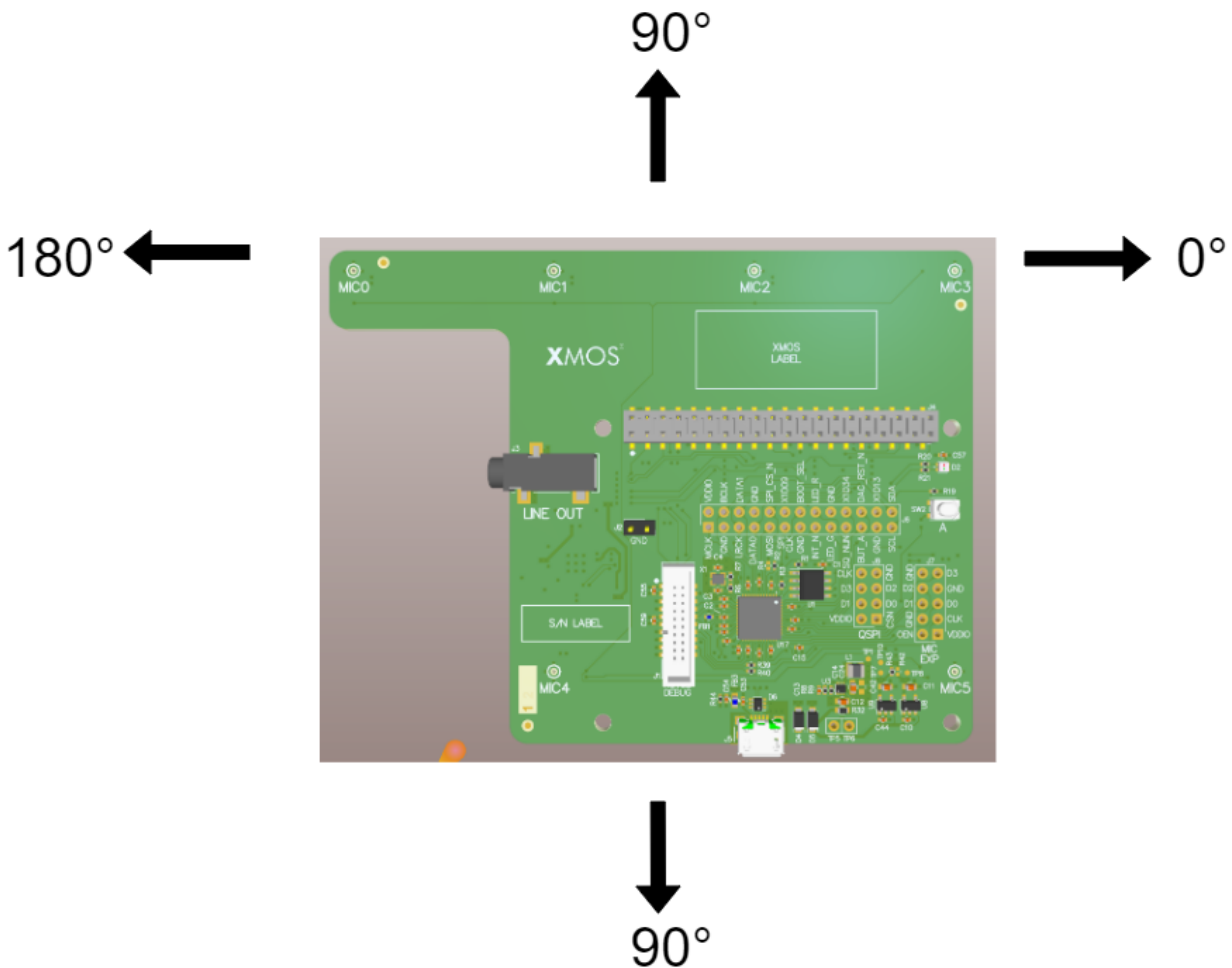

Fig. 3.3: Azimuth angle in linear configuration (note - 0 to 180 degrees only)



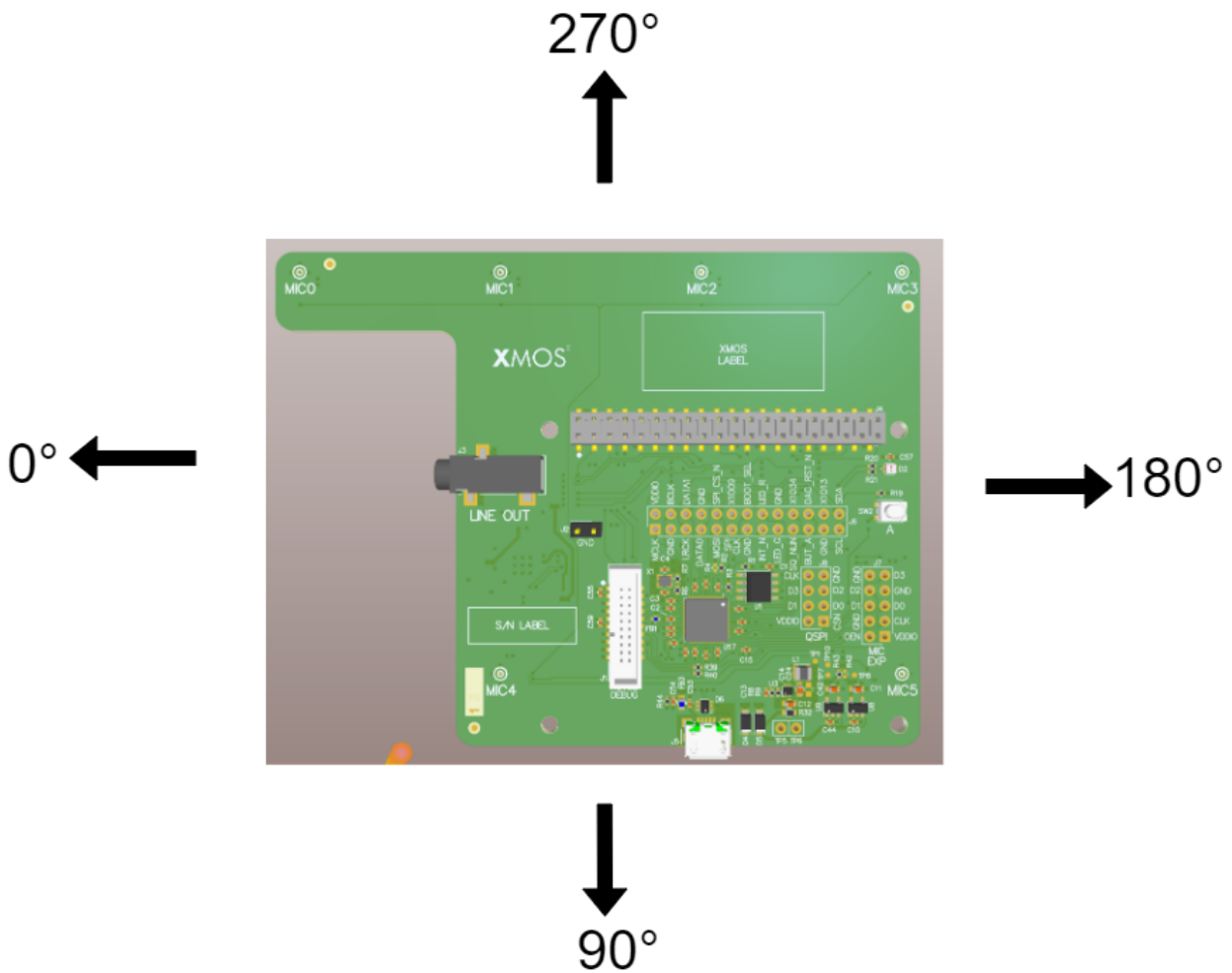

Fig. 3.4: Azimuth angle in square configuration

During post-processing the speech energy (spenergy) is also calculated for each of the 4 beams. This value indicates whether speech is present in the beam as well as the amplitude. Non-zero spenergy means that the beam probably contains speech. Higher values indicate louder or closer speech, however noise, echo and reverb can cause the energy level to decrease. These 4 floating point values can be read directly using the `xvf_host` command `AEC_SPENERGY_VALUES`. The 4 values map to the beams in the same manner described for `AEC_AZIMUTH_VALUES`.

For situations where the speaker placements are known and will not change, the focused beams, numbered 0 and 1, can also be fixed in a specific direction. The user can configure the azimuth and elevation angles of each beam.

---

**Note:** When using fixed mode, both focused beams must be fixed. It is not possible to fix only one.

---

To manage the beams in fixed mode the following commands are used:

- `AEC_FIXEDBEAMSAZIMUTH_VALUES`: writes and reads back the azimuth values in radians for the beams in fixed mode.
- `AEC_FIXEDBEAMSELEVATION_VALUES`: writes and reads back the elevation angles in radians for the beams in fixed mode.
- `AEC_FIXEDBEAMSONOFF`: enables and disables the fixed focused beam mode.
- `AEC_FIXEDBEAMNOISETHR`: writes and read back the threshold value for updating the noise canceller when fixed beam mode is enabled. A higher value indicates that the noise canceller may update when

---

the free running beam is close to the fixed beam. A lower value indicates that the noise canceller may update when the free running beam is further away from the focused beam.

- AEC\_FIXEDBEAMSGATING: enables or disables gating on the fixed beams. With gating, fixed beams with a low speech energy will be muted. In addition, only one fixed beam will be active at a time; if both report a high enough speech energy, the one with the lower energy will be muted.
- AEC\_SPENERGY\_VALUES: this is the same command used for the non-fixed beams, and four values are reported. If fixed focused beam mode is enabled by AEC\_FIXEDBEAMSONOFF, the first two values are the speech energies of the fixed beams.

---

**Note:** Since the azimuth angle provided by the DoA function is dependent on the measurements of the acoustic path, the values reported by AEC\_AZIMUTH\_VALUES might not precisely match the fixed beam azimuth value.

---

### 3.5.2 Using azimuth data For Direction of Arrival indication

The auto selection algorithm will switch between beams rapidly in some circumstances. The two focused beams update relatively slowly, but the free running beam is designed to be sensitive so that it can rapidly pick up the speech signal for a new talker entering the soundscape. As a result it can also pick up any noise signals present.

To provide maximum flexibility to system designers, the XVF3800 provides raw azimuth data which can be used as required. XVF3800 also computes an additional azimuth value which combines speech energy and azimuths to provide a single value which indicates the direction and presence of a speaker. This value can be read using the command AUDIO\_MGR\_SELECTED\_AZIMUTHS. The command returns 2 values, the first of which is the processed azimuth which will be NAN if there is no speech, otherwise it will be the azimuth of the current speaker. The second is the current azimuth of the auto select beam.

A script, `doa_plot.py`, is included in the source release bundle. It uses the host app to visualise the current azimuths in real time. The script can be called using the `xvf_tools.py` which is located in `sources`. Run the following command:

```
python3 xvf_tools.py doa_plot --command-help
```

for usage instructions. This command requires a positional argument with the path to the `xvf_host` binary, and a few optional arguments, for example `--protocol` to select the correct communication protocol.

## 3.6 Example Uses

The `xvf_host` tool allows the configuration of the XK-VOICE-SQ66 development kit to be changed during operations. The following examples illustrate some common operations.

### 3.6.1 Output Selection

By default, the left (first) channel of the device's output is the processed output from the XVF3800's AEC and beamforming stage, while the right (second) channel is the raw input from one of the microphones after amplification. This selection provides a good comparison between the raw and processed audio. The selected outputs may be changed by using the *AUDIO\_MGR\_OP\_L* and *AUDIO\_MGR\_OP\_R* commands. These commands each take two integers defining the mux routing settings, described as a pair of (category, source) values.

The available categories and sources are as detailed in [Table 3.2](#).

Table 3.2: Audio manager mux options

Category	Sources
0: Silence	0: Silence. This is the default setting for the right channel output.
1: Raw microphone data - before amplification	0,1,2,3: Specific microphones accessed by index, no system delay applied.
2: Unpacked microphone data	0,1,2,3: Unpacked microphone signals. If using packed input, access packed microphone data through this category. This data is undefined when not using packed input.
3: Amplified microphone data with system delay	0,1,2,3: Specific microphones accessed by index. This category provides the microphone signal passed to the SHF logical cores for processing.
4: Far end (reference) data	0: Far end data received over I <sup>2</sup> S, post sample rate conversion to 16 kHz if required.
5: Far end (reference) data with system delay	0: Far end data received over I <sup>2</sup> S, post sample rate conversion to 16 kHz if required, and with system delay applied.
6: Processed data	0,1: Slow-moving post-processed beamformed outputs, 2: Fast-moving post-processed beamformed output, 3: The "auto-select" beam; chooses the best of the previous three beams as an output, recommended option for selecting the beamformed outputs
7: AEC residual / ASR data	0,1,2,3: AEC residuals for the specified microphone, or ASR output for the specified beam.
8: User chosen channels	0,1: These currently copy the auto-select beam (category 6, source 3) and are the default setting for the left channel output.
9: Post SHF DSP channels	0,1,2,3: All output channels from user post SHF DSP.
10: Far end at native rate	0,1,2,3,4,5: Data passed from I <sup>2</sup> S logical core to Audio Manager logical core. All sources carry useful data if the external interface rate is 48 kHz. Only sources 0 and 1 carry useful data if the external interface rate is 16 kHz. See the Data Plane Detailed Design section in the Programming Guide for information on the interface between these two logical cores.
11: Amplified microphone data before system delay	0,1,2,3: Specific microphones accessed by index.
12: Amplified far end (reference) with system delay	0: Far end data received over I <sup>2</sup> S, post sample rate conversion to 16 kHz if required, and with a configurable fixed gain and system delay applied. This category provides the reference signal passed to the SHF logical cores for processing.



Fig. 3.5 shows the available categories and sources. Inputs to the category multiplexer that have no preliminary multiplexer only support a single source.

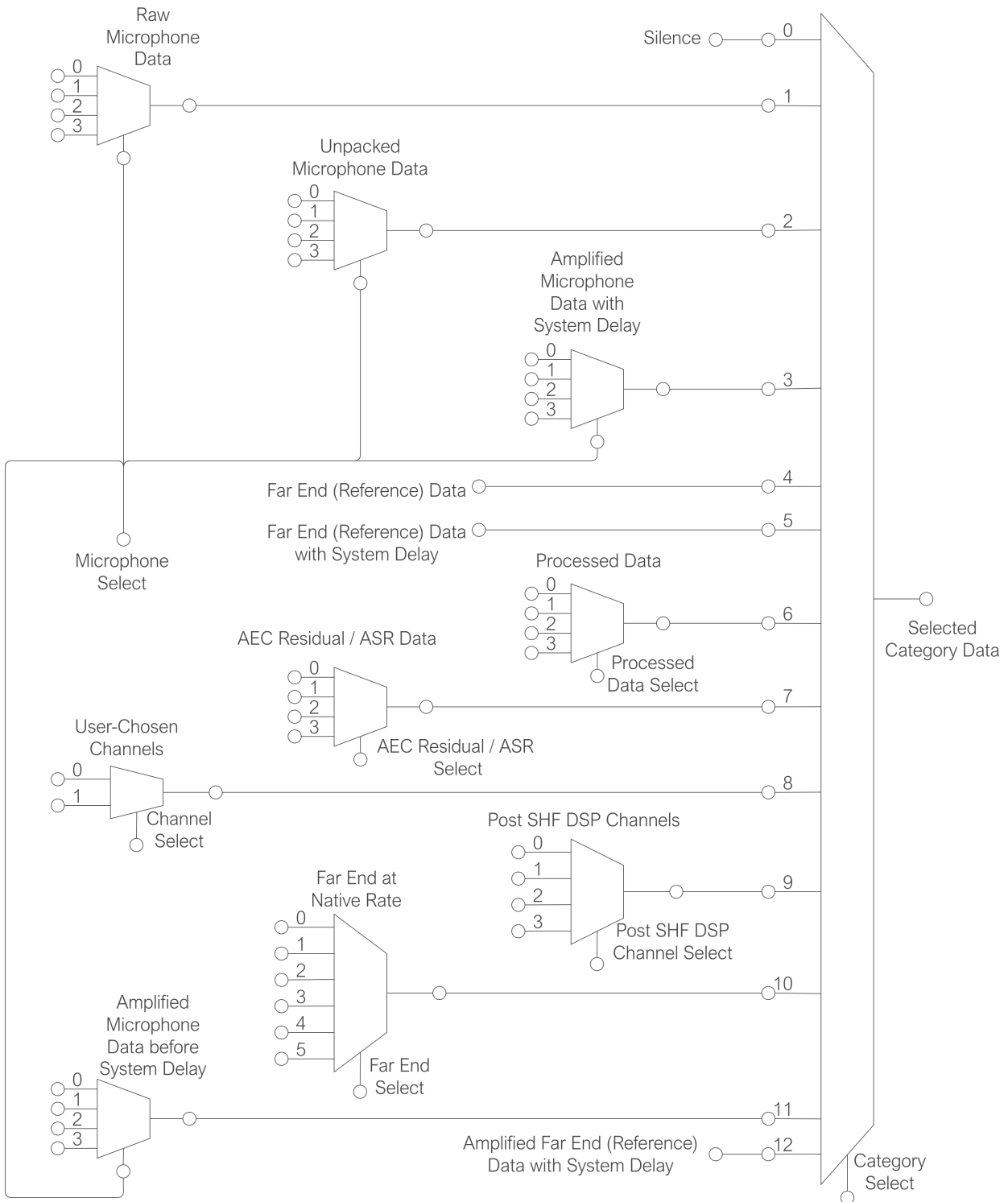

Fig. 3.5: Output Selection Multiplexers

For example, to set the left output to the 4th raw microphone signal (without gain applied), issue the command:

```
(sudo) xvf_host(.exe) AUDIO_MGR_OP_L 1 3
```



---

This will set the left channel to output the 4th (0-indexed) microphone signal of the 4 present. To reset this channel back to its default value, issue:

```
(sudo) xvf_host(.exe) AUDIO_MGR_OP_L 8 0
```

to set the channel to the postprocessed auto-selected output beam.

Similarly, the right channel may be set to any desired category/source; to reset to its default value, issue:

```
(sudo) xvf_host(.exe) AUDIO_MGR_OP_R 0 0
```

## 3.6.2 Setting an Output Pin

The `xvf_host` can be used to configure the General Purpose Outputs on the XVF3800.

To turn on the LED on the XK-VOICE-SQ66 development kit issue the following commands:

```
(sudo) xvf_host(.exe) gpo_port_pin_index 0 6  
(sudo) xvf_host(.exe) gpo_pin_pwm_duty 100
```

To turn it off use:

```
(sudo) xvf_host(.exe) gpo_pin_pwm_duty 0
```

---

**Note:** The `gpo_port_pin_index` selects a port and subsequent `gpo_pin_xxx` commands only act on that pin.

---

## 4 Tuning the Application

---

The measured performance of the XVF3800 depends very heavily on the electrical and acoustic environment of the end product that it is incorporated into. In order to achieve optimal performance, including the ability to pass product certification tests, it is necessary to perform a configuration and tuning process to adapt the firmware to the end product's form factor and hardware design.

The majority of this configuration is intended to ensure optimal performance of the XVF3800 audio pipeline, including the behaviour of the Adaptive Echo Canceller (AEC).

The default tuning parameters have been selected such the XK-VOICE-SQ66 development kit will perform well against the Microsoft Teams V5 "Personal Space Speakerphone" specification. Parameters related to the loudspeaker, such as EQ and the non-linear model, will need to be adjusted for optimal performance. By default these parameters apply no equalisation or non-linear correction. Details on the tuning process are given in the [Tuning the Loudspeaker Appendix](#), along with specific configurations for certain loudspeakers.

The full set of configurable parameters for the XVF3800 is given in the [Control Commands Appendix](#).

This chapter makes extensive use of the `xvf_host` application to control configuration parameters at run-time. For further documentation on this utility, please see the section [Using the Host Application](#). Throughout this document, the `-u [i2c|spi|usb]` parameter to this utility will be omitted for brevity.

To facilitate the tuning process a set of software tools are also supplied to process measurements. The Python scripts in this section make use of the script `xvf_tools.py` which is located in the `sources` folder of the XVF3800 source release package. This program allows the user to call a script from the `sources` folder, by mapping the desired script name to the correct location in the source release package. It is used as follows:

```
python3 xvf_tools.py <script_name without .py extension> [command arguments]
```

and the help menu of the script to run can be printed with:

```
python3 xvf_tools.py <script_name without .py extension> --command-help
```

In the remainder of this section the script to be used will be referred to as a command.

### 4.1 System Preparation

#### 4.1.1 Prerequisites

There are a number of prerequisites that should be met in order to facilitate the tuning process:

- It must be possible to both play arbitrary reference input through the XVF3800 over I<sup>2</sup>S or USB and to record the device's output.
- It must also be possible to access the control interface on the XVF3800, either through I<sup>2</sup>C, SPI, or USB as desired.
- Create a block diagram of the whole system, showing audio path from input through to output and including the XVF3800. This can be used to understand how to optimise and control the performance of the overall product. Ensure that the path from the reference input through to the loudspeaker and from the microphones to the XVF3800, including any gain, EQ, compression, filtering, and limiting applied, are illustrated. Ensure also that the points where control is available over these parameters (and, more importantly, where it is not) is fully understood. [Fig. 4.1](#) provides a block diagram of the audio functions in the XVF3800 to aid in the preparation of this system diagram.
- Ensure a good understanding of the coherence between the individual microphones; see the discussion of [microphone coherence](#) in the acoustic guidelines section for details and requirements on this.

- Further, ensure a good understanding of the delay between the microphones and the reference signal input; see [section on system delay](#) for details, requirements, and terminology surrounding this.
  - This delay should remain constant while the device is running. Any inconsistency in this delay will result in severely degraded algorithmic performance.
  - If this delay should change between device reboots, for example due to any front-end processor used to receive the far-end signal, it is important that the device remain causal.
- Care should be taken that samples not be dropped between the device’s reference audio input and the XVF3800.
  - In addition, ensure that any clocking jitter on the interface that carries the reference signal, such as I<sup>2</sup>S or a USB interface, is minimised.
- Access to the IEEE 269-2010 reference signals is useful for representative clear speech signals. Alternative speech signals may be found from the ITU, in particular the files associated with Recommendation P.501, which at time of writing may be acquired from the [webpage for this ITU recommendation](#). Files from these two sets will be referred to in this document by filename.
- All the tuning tools and the audio tracks are included in the release package in the directories below or their subdirectories:
  - sources/modules/fw\_k\_xvf/modules/eq\_filter\_tuning/eq\_filter\_tuning/
  - sources/modules/fw\_k\_xvf/modules/tuning/
  - sources/app\_xvf3800/nl\_model\_gen/

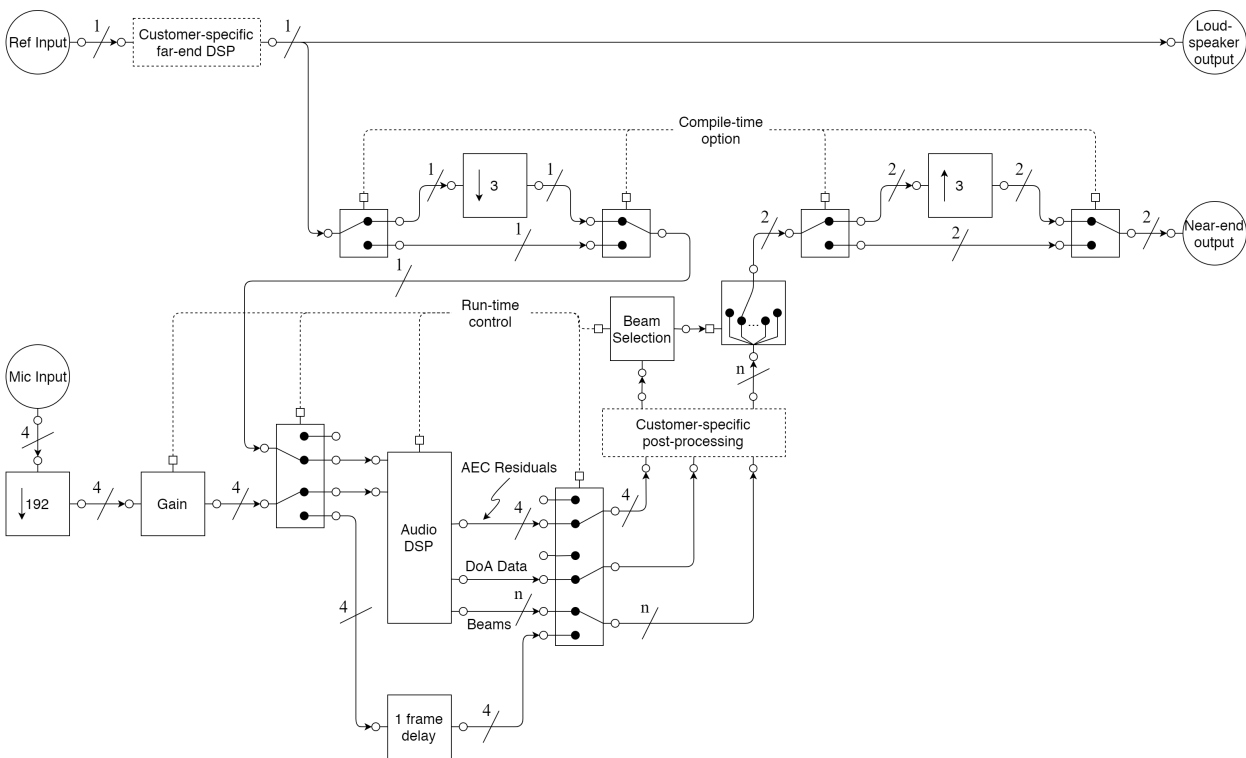

Fig. 4.1: XVF3800 audio block diagram

- Install or update the following tools and python modules to enable the tuning scripts to run:
  - Audacity
  - Python3
  - python modules: see list in *requirements\_build.txt*
  - sox



---

## 4.1.2 Initial Parameter Setting

There are a selection of parameters that should be chosen before the tuning process starts. This guide does not provide a process by which to select a value for these parameters:

- **AEC\_HPFFONOFF:** This sets a high-pass filter (HPF) on the microphone signals as they enter the processing block; this takes the form of a 4th order Butterworth filter, and therefore has a -80 dB per decade rolloff. The corner frequency (-3 dB point) for this HPF may be set to 70 Hz, 125 Hz, 150 Hz, 180 Hz, or the filter may be disabled. The use of a high pass filter is recommended to avoid transmitting low frequency noise outside of the speech band. The HPF frequency should be set such that the combined system cutoff (acoustic enclosure and DSP HPF) is below the minimum frequency required by the specification. These typically require the system to be flat above 200Hz.
- **AEC\_FAR\_EXTGAIN:** This parameter informs the audio pipeline how much external gain has been applied to the AEC reference signal. The value that this parameter should take is coupled to the volume control of the device; if the device attenuates the signal by e.g. -6 dB, this value should be set to -6. In the UA device variant, when the host sets the output volume, the AEC\_FAR\_EXTGAIN is internally set to be the same as the gain set by the host, so the user shouldn't need to set this command externally. In the I<sup>2</sup>S variant of the device, if changing the external gain on the host, the user would manually need to set the AEC\_FAR\_EXTGAIN using the control interface to match the external gain.
- **PP\_LIMITONOFF** and **PP\_LIMITPLIMIT:** A power limiter may be inserted in line with the processed audio outputs from the audio pipeline using PP\_LIMITONOFF. The power threshold used may be set with the PP\_LIMITPLIMIT command. If the output energy is predicted to exceed PP\_LIMITPLIMIT, compression is applied to the outputs to avoid this. The output should not clip under reasonable circumstances.

## 4.1.3 Initial Tests

The first step in tuning the product is to ensure that the send, receive, and loopback paths through the XVF3800 are electrically stable and that the XVF3800 has a stable control interface.

### 4.1.3.1 Input Path

This test will attempt to verify that a signal injected into the device through the device's intended input path successfully reaches the XVF3800. This tests path 1 in [Fig. 4.2](#). If possible, inject a test signal (such as white noise) through the device's reference audio input path and monitor the signal path immediately prior to the XVF3800. Consider disabling the device's loudspeaker for the duration of this test if the test signal chosen would cause auditory discomfort. Verify that the test signal is observed.

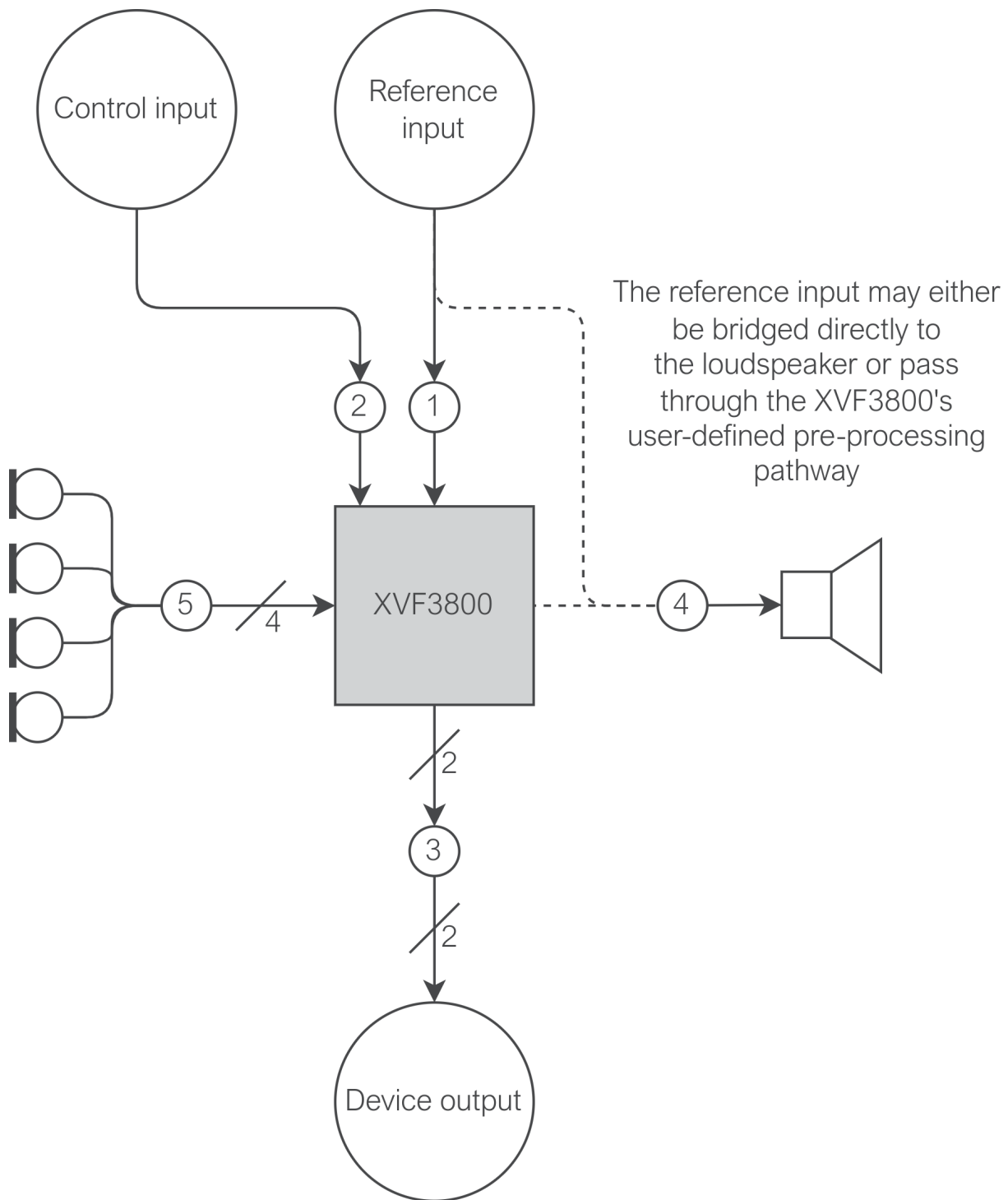

Fig. 4.2: Top-level schematic showing the 5 input and output paths of the XVF3800

In Fig. 4.2, numbered points correspond to the suggested order of testing.

**Note:** If direct monitoring of the signal path immediately prior to the XVF3800 is not feasible, it is permissible to skip this test; its function is implied in later tests.

---

### 4.1.3.2 Control Path

This test will attempt to verify that the XVF3800 has a stable control interface. This tests path 2 in [Fig. 4.2](#). Following the guidelines in [Using the Host Application](#), issue:

```
(sudo) xvf_host(.exe) VERSION
```

and ensure that the device returns "3 2 1".

### 4.1.3.3 Output Path

This test will attempt to verify that a signal injected into the XVF3800 is output faithfully from the XVF3800 and successfully output by the device. This tests paths 1 and 3 in [Fig. 4.2](#). Set up the XVF3800's output mux as follows to loop back any data received:

```
(sudo) xvf_host(.exe) AUDIO_MGR_OP_UPSAMPLE 0 0  
(sudo) xvf_host(.exe) AUDIO_MGR_OP_ALL 10 0 10 2 10 4 10 1 10 3 10 5
```

---

**Note:** As the signals produced here are by definition at the I<sup>2</sup>S or USB sample rate, they do not require the use of the upsampler in the case of a 48 kHz connection, and therefore we explicitly unset the AUDIO\_MGR\_OP\_UPSAMPLE flags (set to 1 by default in a 48 kHz configuration). If using a 48 kHz interface, be sure that AUDIO\_MGR\_OP\_UPSAMPLE is reset appropriately to accommodate signals that are generated at 16 kHz, including the processed output signals.

---

Inject a test signal (such as white noise) through the device's reference audio input path and monitor the signal on the device's communications output. Verify that the output matches the input signal. This should have a fixed delay, but should otherwise be the raw I<sup>2</sup>S data, after any customer-specific pre-processing DSP has been applied. Consider disabling the device's loudspeaker for the duration of this test if the test signal chosen would cause auditory discomfort.

### 4.1.3.4 Speaker Operation

It is advised that the linearity, stability (even operation over the desired frequency range), output level, and total harmonic distortion (THD) be characterised for the loudspeaker(s) in use in the product. Play a test file, such as an IEEE Reference file, through the loudspeaker and observe the output level. The loudspeaker level should be adjusted such that it meets the desired output level target. This tests path 4 in [Fig. 4.2](#).

---

**Note:** The desired loudspeaker output level is usually specified by product certification requirements such as those constructed by Amazon, Microsoft, or Zoom. Refer to your desired certification requirements for appropriate targets for this test.

---

With the loudspeaker at an appropriate level, observe that there is not audible distortion or nonlinearity present in the speech signal. With the loudspeaker at its maximum designed level, observe that there remains no audible distortion or nonlinearity present in the speech signal. Some product certification requirements specify performance metrics for the end product when operating with its loudspeaker at maximum volume. Microsoft's requirements currently allow this level to be set at the designer's discretion, while other product certification requirements may state a specific volume or range. Therefore, it is important that the loudspeaker remains clear and undistorted at this level. A quantitative measurement of the system's Total Harmonic Distortion (THD) should be taken to ensure that the loudspeaker is operating as intended. Correct operation of the loudspeaker is essential to the tuning process. Operating the loudspeaker and associated amplifier within their linear region is very important for the tuning process and for optimal algorithmic performance.

For more information on adjusting the loudspeaker output, including inserting any required filters, see the [Tuning the Loudspeaker Appendix](#).

---

### 4.1.3.5 Microphone Operation

Ensure that the microphone assignment is as expected and that they sound natural and artefact-free. This tests paths 3 and 5 in [Fig. 4.2](#).

Set up the XVF3800's output mux as follows to output raw data for microphones 0 and 1:

```
(sudo) xvf_host(.exe) AUDIO_MGR_OP_L 1 0
(sudo) xvf_host(.exe) AUDIO_MGR_OP_R 1 1
```

and set up as follows to output raw data for microphones 2 and 3:

```
(sudo) xvf_host(.exe) AUDIO_MGR_OP_L 1 2
(sudo) xvf_host(.exe) AUDIO_MGR_OP_R 1 3
```

---

**Note:** As the microphone signals are decimated to 16 kHz within the XVF3800's audio manager, the microphone signals require upsampling on a 48 kHz bus - ensure that the AUDIO\_MGR\_OP\_UPSAMPLE flags have been reset after previous testing if using a 48 kHz XVF3800 configuration.

---

Ensure that each microphone is assigned as expected; this can be achieved by e.g. clicking near or tapping each microphone in turn to ensure that the signal is routed to the expected output. If the microphone assignment is not as expected, then the microphone geometry may be incorrect and therefore Direction of Arrival (DoA) information may be incorrect.

Record some near-end signal (such as speech) and analyse the result for undesirable artefacts, such as noise, distortion, or interference. Ensure that speech through each microphone sounds clear and natural. Verify that each microphone is similar in level, for example by examining a power spectral density plot (PSD) of a known near-end source and observing that each microphone signal has a similar total power.

## 4.2 Tuning the XVF3800 Parameters

This section will walk through a typical tuning process, step by step. It is advised that, when appropriate values for each tuning parameter are determined, the device firmware is rebuilt with these values as default and the device is reflashed, this process is described in the section [Building the application](#). It is recommended that the device be restarted at the start of each of these tuning steps.

### 4.2.1 Reference Gain

The AUDIO\_MGR\_REF\_GAIN parameter is provided to control a gain block placed in the reference audio path after the customer-specific pre-processing DSP stage. The reference audio should be amplified such that any peak amplitude losses through the input path (such as attenuation or filtering prior to the XVF3800 or in the customer-specific pre-processing DSP stage) are accounted for. This gain is applied within the audio manager internal to the XVF3800, and therefore does not have an impact on the signal sent to the loudspeaker.

Set up the XVF3800's output mux as follows to output pre- and post-gain data for the reference input:

```
(sudo) xvf_host(.exe) AUDIO_MGR_OP_L 4 0
(sudo) xvf_host(.exe) AUDIO_MGR_OP_R 12 0
```

This will set the left output as the pre-gain reference input, and the right output as the post-gain reference input. With default device configuration, these should be the same.

Depending on the device sample rate, copy from `sources/modules/fw_k_xvf/modules/tuning/audio_files` the track `white_noise_0dbfs_2ch_16khz.wav` or `white_noise_0dbfs_2ch_48khz.wav`. Inject the white noise signal into the device's reference input and verify that the reference input observed by the XVF3800 is the

---

same level, i.e. with a peak of 0 dB<sub>FS</sub>. If this is not the case, tune AUDIO\_MGR\_REF\_GAIN such that the post-gain reference input has the largest value possible, up to 0 dB<sub>FS</sub>.

---

**Note:** White noise is chosen in this example as it contains equal energy in all frequency bands. This is important in cases where e.g. a filter is applied to the reference signal before the XVF3800 or in the customer-specific pre-processing DSP block. In these cases, a single tone may be attenuated more than other tones, and tuning to this specific frequency may lead the device to clip at other frequencies. If no such filter is applied, a tone (such as the tracks `sine_1khz_0dbfs_2ch_16khz.wav` or `sine_1khz_0dbfs_2ch_48khz.wav`) may be chosen instead, which has a more predictable peak amplitude in a shorter timeframe.

---

**Note:** It is very important that the reference input can never digitally clip. If this is a risk, it is permissible to leave some headroom in this parameter of approximately 1 - 2 dB.

---

## 4.2.2 Microphone Gain

Similarly, the AUDIO\_MGR\_MIC\_GAIN parameter is provided to control a gain block placed in the input path from the microphones. The same gain is applied to all four microphones. To tune AUDIO\_MGR\_MIC\_GAIN, set the left output as a selected microphone post-gain - for example, microphone 0 - and the right output as the reference audio post gain:

```
(sudo) xvf_host(.exe) AUDIO_MGR_OP_L 3 0
(sudo) xvf_host(.exe) AUDIO_MGR_OP_R 12 0
```

Depending on the device sample rate, copy from `sources/modules/fwkw_xvf/modules/tuning/audio_files` the track `white_noise_0dbfs_2ch_16khz.wav` or `white_noise_0dbfs_2ch_48khz.wav`. Inject the noise signal into the device's reference input and observe the relationship between the post-gain reference signal and the post-gain microphone signal. Tune AUDIO\_MGR\_MIC\_GAIN such that the microphone signal has a peak amplitude 6 dB below the reference signal. Observe the other 3 microphone channels and ensure that none exceed 6 dB below the reference signal.

---

**Note:** If the microphone signal becomes louder than 6 dB below the reference signal, the AEC may converge to coefficients in the frequency domain greater than 0 dB. This has a significantly negative effect on algorithmic performance, and may lead to instability.

---

Consider rotating the device, placing it near walls or corners, placing objects in front of the microphones, or exercising other realistic use-cases. Ensure that in each of these cases the post-gain microphone signal does not exceed 6 dB below the reference signal.

## 4.2.3 Silence level

The AEC\_AEC\_SILENCE\_LEVEL parameter sets a power threshold for signal detection in the AEC. If there is known e.g. ADC induced noise in the reference audio signal line, this parameter may be set to avoid the AEC adapting to this noise. This parameter is set by default to 0.00000001, representing a -80 dB<sub>FS</sub> noise floor; note that 0 dB<sub>FS</sub> white noise would be represented as having a power multiplier of 1. To tune this parameter, set up the XVF3800's output mux as follows to output post-gain data for the reference input:

```
(sudo) xvf_host(.exe) AUDIO_MGR_OP_L 12 0
(sudo) xvf_host(.exe) AUDIO_MGR_OP_R 0 0
```

Depending on the device sample rate, copy from `sources/modules/fwkw_xvf/modules/tuning/audio_files` the track `silence_2ch_16khz.wav` or `silence_2ch_48khz.wav`. Inject this silence signal into the device's ref-

reference input and observe the post-gain output. This will show any system noise between the reference input and the audio processing pipeline. Calculate the average power in a short segment (e.g. 10 seconds), typically by taking the mean of the squared values of each sample. This is the desired low bound for AEC\_AECSILENCELEVEL; select a value a nominally small amount (e.g. 1 to 2 percent) higher than this.

#### 4.2.4 System Delay

With an appropriate gain structure, the next step in the tuning process is to ensure that the product is *causal*; that is to say, that an event played in the reference audio stream and over the loudspeaker is received by XVF3800 reference input an appropriate amount of time (in samples) before the coupled signal returns through the microphone path. This is very important; if the system is *acausal* (a signal played into the room in the reference audio stream is received in the microphone inputs before it is received in the reference input) then effective echo cancellation cannot be achieved. By the same token, the microphones should not be overly delayed compared to the reference signal; each coefficient in the AEC corresponds to a sample in the time domain, and so if the microphone signal is overly delayed, fewer AEC coefficients will be of use and the overall behaviour of the AEC will be less optimal.

Expanding on the top-level diagram featured in Fig. 4.2, a more realistic understanding of the main two paths for the reference signal to take can be seen in Fig. 4.3. If the reference signal takes path A pictured, where it is passed through the XVF3800 before it is then sent to the loudspeaker, then it is highly unlikely that the device will become *acausal*. If instead the signal is sent via path B pictured, where the reference input is passed to the loudspeaker assembly prior to sending on to the XVF3800, an arbitrary reference path delay has the potential to push the device into *acausality* if it exceeds the echo path delay between the loudspeaker and the microphones.

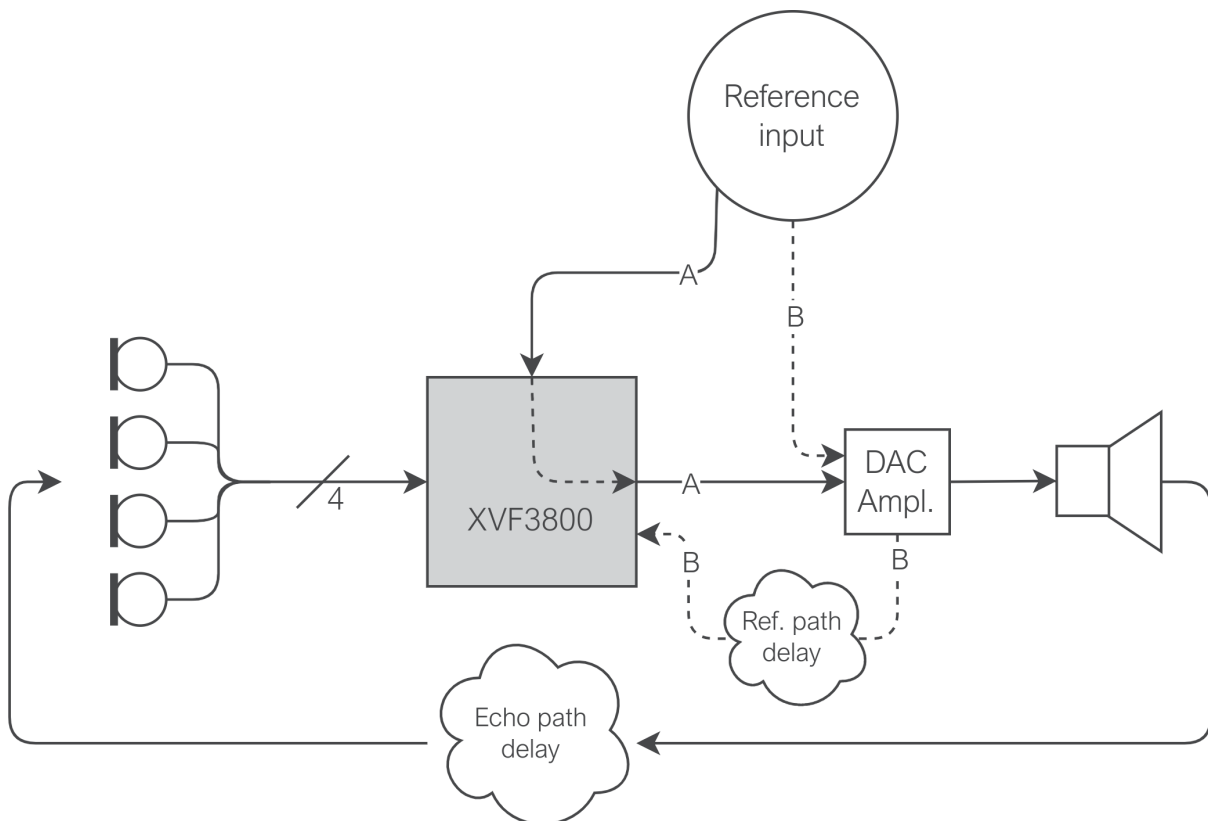

Fig. 4.3: A more detailed representation of the reference input path for the XVF3800, showing both path A where the signal is routed through the XVF3800 (and any customer-specific pre-processing) before sending to the loudspeaker, and path B where the signal is routed via the loudspeaker before it reaches the XVF3800.

---

In an ideal system, the delay between the reference and microphone signals should be at or less than 40 samples. The `AUDIO_MGR_SYS_DELAY` parameter allows a configurable delay to be applied to either the microphone signal or the reference signal to achieve this 40 sample difference.

A positive value for this parameter, measured in number of samples, sets a delay on the reference signal; if the delay between microphones and reference is too large, setting this value as positive will reduce this difference. A negative value sets a delay on the microphone signals. Setting this delay to a negative value is the recommended method to correct acausality in the device. Note that this will naturally increase the overall delay from input to output through the device.

To estimate the current causality of the system, use the `mic_ref_correlate` command provided. To obtain the required signals for this script, set the output mux as follows:

```
(sudo) xvf_host(.exe) AUDIO_MGR_OP_L 3 <microphone number>
(sudo) xvf_host(.exe) AUDIO_MGR_OP_R 5 0
```

---

**Note:** Causality must be checked for all four microphones, as each of the microphones may have a different echo path delay. Calculate correlation between each microphone and the reference in turn.

---

Depending on the device sample rate, copy from `sources/modules/fw_k_xvf/modules/tuning/audio_files` the track `silence_white_noise_0dbfs_silence_2ch_16khz.wav` or `silence_white_noise_0dbfs_silence_2ch_48khz.wav`; these tracks contain 5s of silence, followed by 10s of 0 dB<sub>FS</sub> white noise, followed by 5s of silence. Pass this through the reference input and record the device output in your chosen audio tools, e.g. Audacity. Save the result as a 2 channel WAV file with the left channel (the post-delay post-gain microphone) as channel 0 and the right channel (the looped-back post-delay post-gain reference signal) as channel 1. Use this as the input to the script:

```
python3 xvf_tools.py mic_ref_correlate <input wav file.wav>
```

A diagram similar to [Fig. 4.4](#) should be generated.

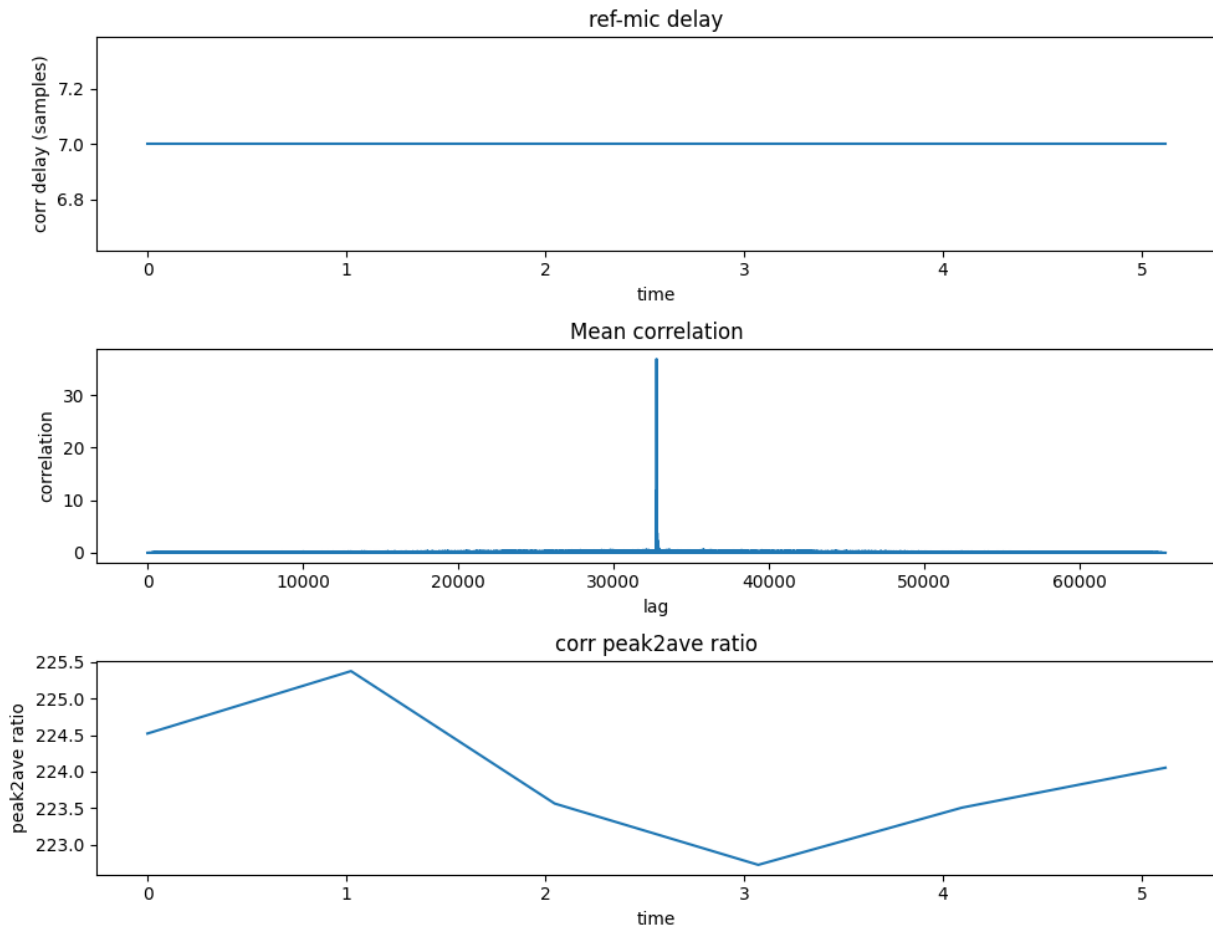

Fig. 4.4: Example output of mic\_ref\_correlate

Fig. 4.4 shows a 7 sample delay between microphones and the reference signal. This system is causal, but only just. Setting `AUDIO_MGR_SYS_DELAY` to around -30 will bring the system to the recommended headroom. This procedure may be repeated after the `AUDIO_MGR_SYS_DELAY` parameter has been set to verify that the system remains causal and has the desired (less than 40 samples) delay between the reference and microphone inputs. Ensure that the device is causal for all four microphones.

## 4.2.5 AEC Operation

To verify the AEC's operation, play through the reference input a representative test sample, such as `IEEE_269-2010_Male_mono_48_kHz.wav`.

Allow the AEC to converge. The convergence of the AEC may be monitored by use of the `AEC_AECCONVERGED` parameter. This is a read-only parameter. Issuing:

```
(sudo) xvf_host(.exe) AEC_AECCONVERGED
```

will present the return value as:

```
AEC_AECCONVERGED [0|1]
```

If the returned value is 1, the AEC has converged.

**Note:** Once this value is set to 1 internally, it is never reset, even if a significant path change or other circum-



stance forces a significant change in the AEC.

When the AEC reaches convergence (which is expected to take less than 30 seconds), read the AEC coefficients from the device:

```
(sudo) xvf_host(.exe) (-gf | --get-aec-filter) [filename.bin]
```

This operation generates 4 separate files <filename.bin>.f0.m[0..3], one per AEC channel. These four files can be analysed in one operation with the *read\_aec\_filter* command provided:

```
python3 xvf_tools.py read_aec_filter <filename.bin>
```

This should generate a plot as shown Fig. 4.5.

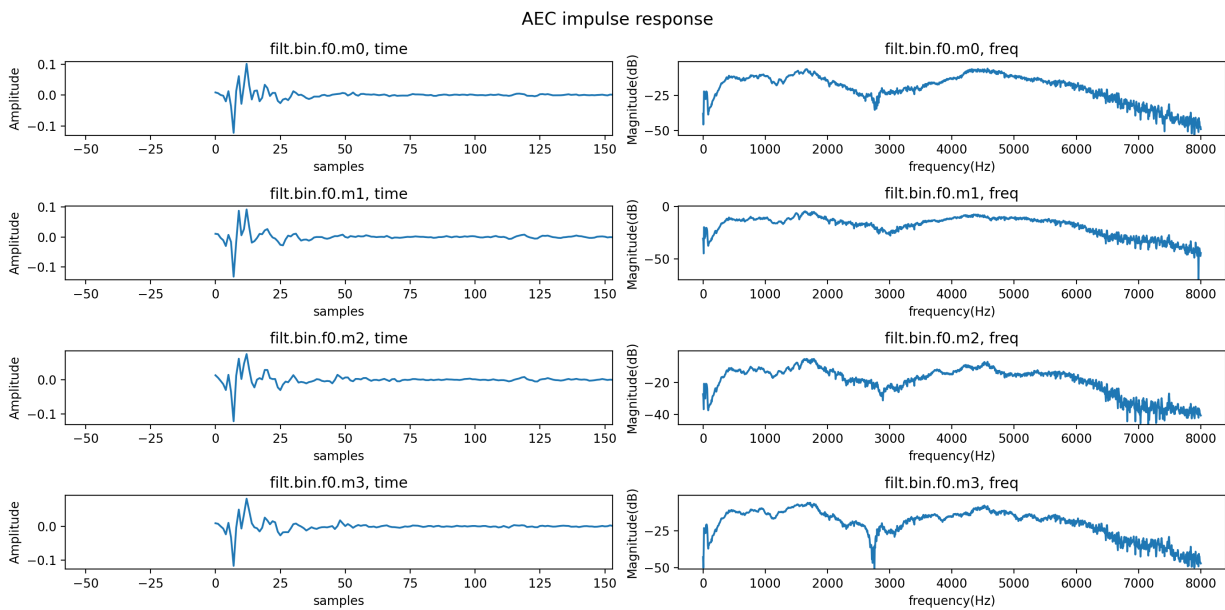

Fig. 4.5: Example output of *read\_aec\_filter*

It will also print in the console the peak and mean coefficient values in the frequency domain. To avoid excessive gain through the AEC filter, the mean coefficient value must be below 0 dB for all four microphones. If it is not, reduce `AUDIO_MGR_MIC_GAIN` to satisfy this. It is recommended to start with a `AUDIO_MGR_MIC_GAIN` value that gives a peak coefficient value close to 0 dB. The optimal AEC performance may occur with either the peak or the mean coefficient value at 0 dB.

Observe the period between 0 and 100 samples in the time domain. There should be a strong first peak, as shown in Fig. 4.5. The location of this peak in the time domain should be the same as the previously observed delay between each microphone and the reference input. If this value is significantly above 40 samples, increase `AUDIO_MGR_SYS_DELAY` to reduce this. If the time domain response starts with a strong peak at the first sample, this could be an indication that your system is acausal - reduce `AUDIO_MGR_SYS_DELAY` to attempt to bring the full time domain response into view.

## 4.2.6 AGC Configuration

The audio pipeline includes an automatic gain controller (AGC) which is applied equally to all four processed outputs from the XVF3800.

This is controlled by four parameters: PP\_AGCGAIN, PP\_AGCMAXGAIN, PP\_AGCDESIREDLEVEL, and PP\_AGCONOFF.

- PP\_AGCGAIN both controls and reports the current multiplicative gain applied to the output beams by the AGC. The value set as the product default is the initial value. When the AGC is active, this value is then dynamically adjusted to attempt to meet the specified output power.
- PP\_AGCDESIREDLEVEL is the parameter that sets this desired output power. The signal power of the free-running beam is measured and compared to the value of PP\_AGCDESIREDLEVEL, and PP\_AGCGAIN is adjusted to attempt to meet it.
- PP\_AGCMAXGAIN is the maximum value that PP\_AGCGAIN may take in operation.
- PP\_AGCONOFF determines whether the AGC is permitted to adapt or whether the value of PP\_AGCGAIN is fixed.

---

**Note:** It is important to note that the gain specified by PP\_AGCGAIN is always applied, regardless of the value of PP\_AGCONOFF; PP\_AGCONOFF will only control whether or not this value is permitted to change during operation.

---

To set appropriate default values for these parameters, set the device's output mux to output the free-running beam:

```
(sudo) xvf_host(.exe) AUDIO_MGR_OP_L 6 2
(sudo) xvf_host(.exe) AUDIO_MGR_OP_R 0 0
```

Initialise the parameters to sensible default values:

```
(sudo) xvf_host(.exe) PP_AGCGAIN 1.0
(sudo) xvf_host(.exe) PP_AGCMAXGAIN 1000
(sudo) xvf_host(.exe) PP_AGCONOFF 1
```

Play a near-end signal, such as IEEE\_269-2010\_Male\_mono\_48\_kHz.wav, at a nominal level and at a nominal distance. The exact specification for this should be determined by the desired certification. Allow PP\_AGCGAIN to converge on a value, record the device output, and observe the output level. xvf\_tools.py provides the command agc\_gain\_plot to visualise the current AGC value in real time. Run the following command:

```
python3 xvf_tools.py agc_gain_plot --command-help
```

for usage instructions. This command requires a positional argument with the path to the xvf\_host binary, and a few optional arguments, for example --protocol to select the correct communication protocol.

Should the device output be too quiet or too loud for the desired certification specification, alter PP\_AGCDESIREDLEVEL and allow PP\_AGCGAIN to reconverge.

Once the device output level is as desired, record the stable value of PP\_AGCGAIN. This should then be set as the product's default value for PP\_AGCGAIN.

PP\_AGCDESIREDLEVEL can be converted to a target level in dBov or dBm0 as follows:

```
level_dBov = 10*log10(PP_AGCDESIREDLEVEL)
level_dBm0 = 10*log10(PP_AGCDESIREDLEVEL) + 6
```

(Note that definitions of dBFS vary between standards as either dBFS == dBov or dBFS = dBov + 3).

To configure PP\_AGCMAXGAIN, reduce the near-end signal by 10 dB and repeat the above process, allowing PP\_AGCGAIN to converge on a stable value. This should become the product's default value for PP\_AGCMAXGAIN, and will set the maximum amplification possible by the device.

Check the device performance with quieter speech. If the level is too low, PP\_AGCMAXGAIN should be increased. Check the device performance without speech. If background noise is amplified too much when there is no

---

speech, PP\_AGC\_MAXGAIN should be reduced. There is likely to be a compromise between avoiding unwanted amplification of background noise and making very quiet speech sufficiently loud.

---

**Note:** It is not recommended to change the AGC time constants. Increasing their speed can result in level fluctuations during speech. For reference, their interactions are described below.

---

When the AGC gain is being increased (changing from a close speaker to a far-away one):

- If PP\_AGCGAIN is less than PP\_AGCALPHAFASTGAIN, switch from PP\_AGCALPHASLOW to PP\_AGCALPHAFASTGAIN
- This will make the AGC gain ramp up faster by using a faster time constant
- By default PP\_AGCALPHAFASTGAIN = 0, so PP\_AGCALPHASLOW is always used.

When the AGC gain is being decreased (changing from a far-away speaker to a close speaker):

- If the instantaneous input power is higher than the smoothed value, switch from PP\_AGCTIME to PP\_AGCFASTTIME
- This will make the AGC gain ramp down faster by using a faster time constant, and can reduce clipping during sudden loud speech.
- By default PP\_AGCTIME = 0.9 and PP\_AGCFASTTIME = 0.6.

## 4.2.7 Emphasis

The rate at which the AEC converges can be optimised by compensating for the spectral characteristics of the reference signal. If the signal has significant low-frequency energy but proportionally less high-frequency energy, this will affect the AEC's rate of convergence in the high frequencies, and therefore rate of convergence overall. An optional high shelf boost may be applied to the microphone inputs using the AEC\_AECEMPHASISONOFF parameter.

Play a representative voice sample such as IEEE\_269-2010\_Male\_mono\_48\_kHz.wav as the reference audio and capture the post-gain, post-delay reference signal:

```
(sudo) xvf_host(.exe) AUDIO_MGR_OP_L 5 0
(sudo) xvf_host(.exe) AUDIO_MGR_OP_R 0 0
```

Perform a Fourier transform using Audacity, or equivalent, and identify the peak magnitude value. Compare this to the magnitude of the signal at 8 kHz. It is expected that the magnitude of the signal at 8 kHz will be less than the peak magnitude. If they have similar magnitudes, set AEC\_AECEMPHASISONOFF to 0. If the difference in magnitudes is around or greater than 8 dB, set AEC\_AECEMPHASISONOFF to 1. If the difference is around or greater than 40 dB, set AEC\_AECEMPHASISONOFF to 2.

The impact of tuning this parameter may be observed by measuring the AEC convergence speed. From a fresh restart, set the following parameters to output clear AEC residuals from a selected pair of microphones:

```
(sudo) xvf_host(.exe) PP_MIN_NS 1.0
(sudo) xvf_host(.exe) PP_MIN_NN 1.0
(sudo) xvf_host(.exe) PP_ECH00NOFF 0
(sudo) xvf_host(.exe) PP_NLATTEN0NOFF 0
(sudo) xvf_host(.exe) PP_AGC0NOFF 0
(sudo) xvf_host(.exe) AUDIO_MGR_OP_L 7 [microphone number]
(sudo) xvf_host(.exe) AUDIO_MGR_OP_R 7 [microphone number]
```

Play a representative voice sample such as IEEE\_269-2010\_Male\_mono\_48\_kHz.wav as the reference input on a loop for around 60 seconds. Capture the device output for this whole period (around 60 seconds); these will be the AEC residuals generated. Observe the spectrogram of the output signal and verify that the AEC converges evenly for all frequencies; that is to say, over the time that the AEC is converging, the

---

high frequencies should converge as quickly as the low frequencies. It should not be observed that the high frequencies converge quicker or slower.

## 4.2.8 MGSCALE

The PP\_MGSCALE parameter controls additional noise suppression that is applied during periods of far-end activity. The aim is to optimise speech clarity output from the device during periods of stationary far-end activity, while also ensuring that there is good echo suppression in periods of non-stationary far-end activity. An undesirable scenario may arise if there exists unintended low-level noise in the reference signal, from e.g. ADC noise in the reference path. In this scenario, the low-level noise may be erroneously detected as far-end speech; the device may then incorrectly detect that double-talk is present and overly suppress near-end speech. The PP\_MGSCALE parameter configures where this trade-off between far-end echo suppression and near-end signal clarity lies.

To tune both the *min* and *max* values for the PP\_MGSCALE parameter, set the following:

```
(sudo) xvf_host(.exe) PP_GAMMA_E 1.0
(sudo) xvf_host(.exe) PP_GAMMA_ENL 1.0
(sudo) xvf_host(.exe) PP_GAMMA_ETAIL 1.0
(sudo) xvf_host(.exe) PP_ECHOOFF 1
(sudo) xvf_host(.exe) PP_NLATTENONOFF 0
(sudo) xvf_host(.exe) PP_MIN_NS 1.0
(sudo) xvf_host(.exe) PP_MGSCALE 1 1 1
(sudo) xvf_host(.exe) AUDIO_MGR_OP_L 6 3
(sudo) xvf_host(.exe) AUDIO_MGR_OP_R 0 0
```

Play a representative far-end signal such as IEEE\_269-2010\_Male\_mono\_48\_kHz.wav on loop as the reference input. Provide a just-noticeable stationary near-end noise signal, such as white noise. This should be played at a very low level from a second loudspeaker/source within the room. Observe the device output, including the spectrogram. Increasing the value of *max* - the first parameter to PP\_MGSCALE - will reduce the amount of residual echo. Increase *max* until no further improvements are observed.

---

**Note:** A typical value for *max* will be between 100 and 1000.

---

Set *min* to the derived value for *max* so that the two are equal.

Depending on the device sample rate, copy from `sources/modules/fw_kxvf/modules/tuning/audio_files` the track `silence_2ch_16khz.wav` or `silence_2ch_48khz.wav`. Play the silence track into the reference input, and provide a representative near-end signal such as `IEEE_269-2010_Male_mono_48_kHz.wav`. Subjectively listen to the device output. There may be stationary noise present on the far-end, which may cause erroneous echo suppression and therefore erroneous speech distortion. Reducing *min* can reduce near-end speech distortion at the cost of reduced stationary noise suppression where stationary noise is present in the far-end signal.

## 4.2.9 FMIN\_SPEINDEX

PP\_FMIN\_SPEINDEX is a parameter that controls the frequency-dependent suppression that the device performs in a double-talk environment. In the case of double-talk, the device's output will suppress frequencies below the value of PP\_FMIN\_SPEINDEX more than frequencies above the value of PP\_FMIN\_SPEINDEX

Set the following to output clear AEC residuals from a selected pair of microphones:

```
(sudo) xvf_host(.exe) PP_MIN_NS 1.0
(sudo) xvf_host(.exe) PP_MIN_NN 1.0
(sudo) xvf_host(.exe) PP_ECHOOFF 0
(sudo) xvf_host(.exe) PP_NLATTENONOFF 0
```

(continues on next page)

(continued from previous page)

```
(sudo) xvf_host(.exe) PP_AGCNOFF 0  
(sudo) xvf_host(.exe) AUDIO_MGR_OP_L 7 [microphone number]  
(sudo) xvf_host(.exe) AUDIO_MGR_OP_R 7 [microphone number]
```

Depending on the device sample rate, copy from `sources/modules/fw_k_xvf/modules/tuning/audio_files` the track `white_noise_0dbfs_2ch_16khz.wav` or `white_noise_0dbfs_2ch_48khz.wav`. Play through the reference input the white noise signal, and capture the AEC residuals that are output from the device. Take a Fourier transform of the interval from 40 - 60 seconds, and plot the magnitude of the coefficients. It is expected that there will be an identifiable "peak" in this spectrum in the lower frequencies, which drops back down into the higher frequencies. Set `PP_FMIN_SPEINDEX` to the highest frequency on this initial peak after which there is no further decrease in the amplitude spectrum when compared to higher frequencies; in the spectrum shown in Fig. 4.6 for example, `PP_FMIN_SPEINDEX` should be set to around 1200 (1.2 kHz), as up to this point the amplitudes for frequencies on this peak are greater than any other higher frequency; however, at 5.5 kHz there exists another peak which has greater amplitude than frequencies greater than ~1.2 kHz. If the spectrum appears roughly flat from around 500 Hz onwards, with no significant decrease in amplitude at higher frequencies, leave `PP_FMIN_SPEINDEX` at its default value of 593.75 Hz.

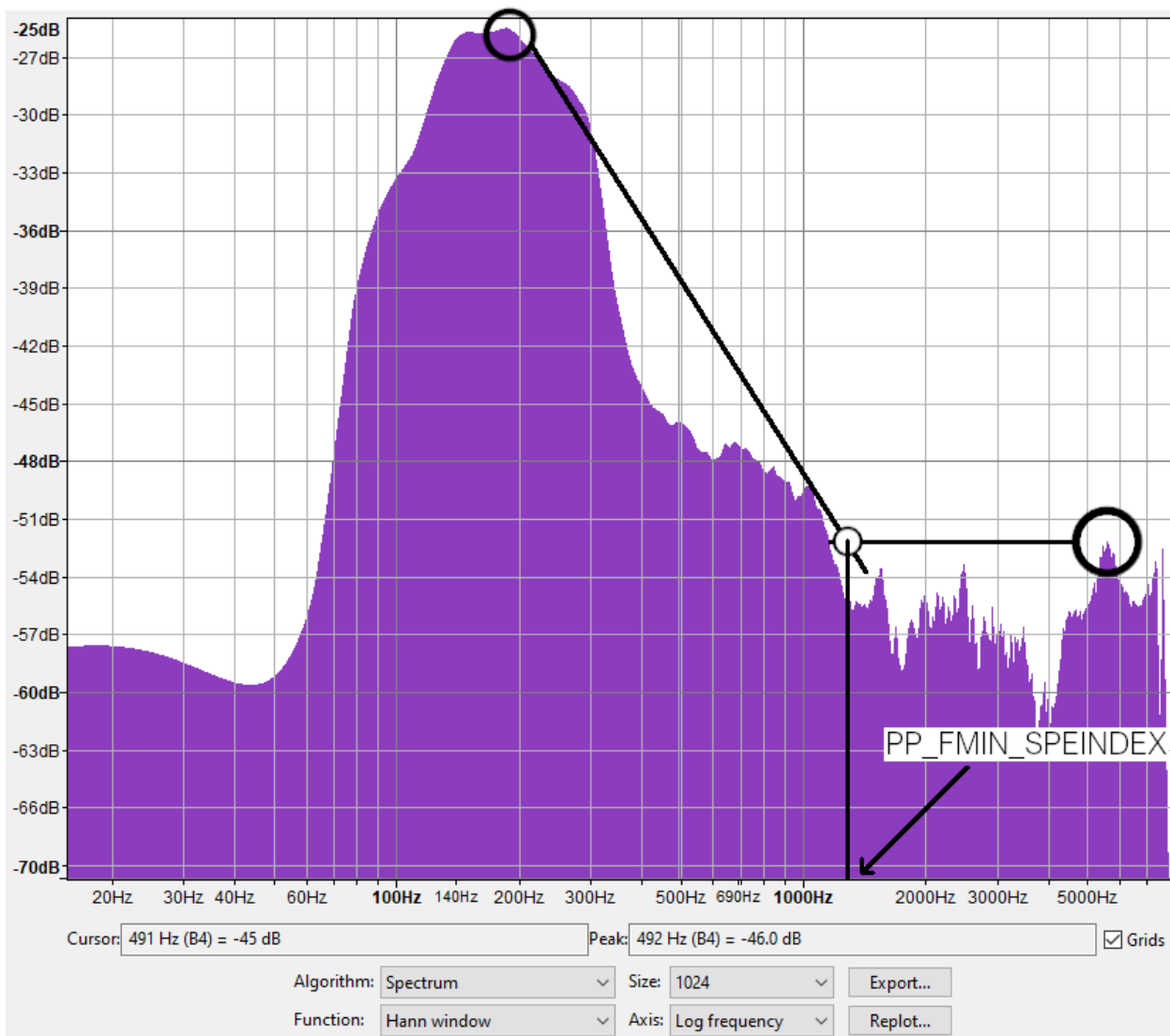

Fig. 4.6: Illustration of the method by which `PP_FMIN_SPEINDEX` may be determined

## 4.2.10 Tuning the Non-Linear Model

### 4.2.10.1 Non-linear Echo

It is likely that in all devices, regardless of the quality of the audio design, there will exist some non-linearities. The aim of non-linear estimation is to model the remaining residual echo after linear echo content (including tail echoes) has been removed. This is achieved in the XVF3800 by use of a self-training non-linear model.

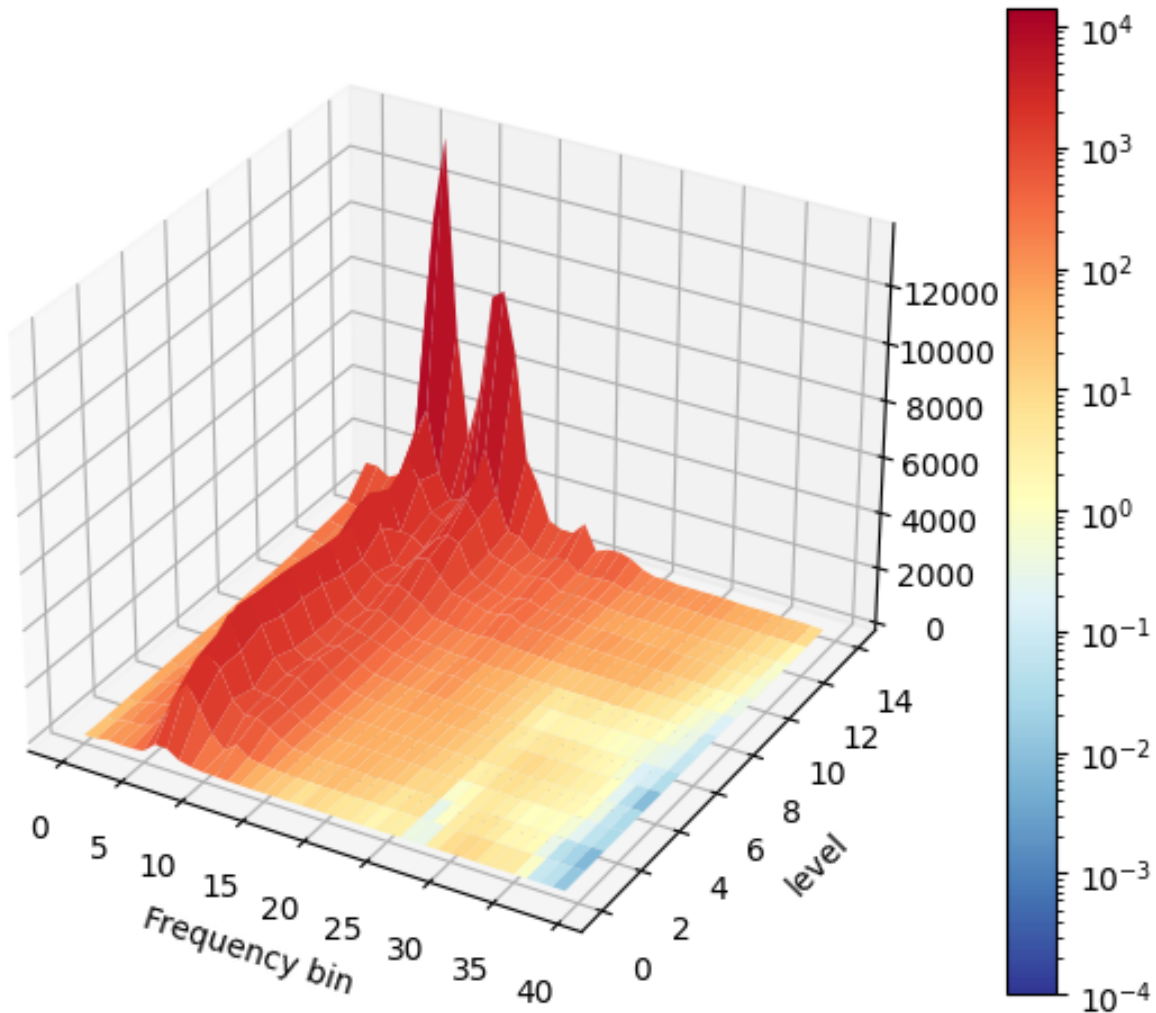

Fig. 4.7: Example non-linear matrix plot.

It is very important to ensure that non-linear model training takes place in a silent environment, and that the environment is ideally anechoic; the RT60 of the environment for example should be as low as possible, and absolutely below 0.3s. As can be seen in Fig. 4.7, it is important that the observed distortion should increase as the output level increases. If the distortion is high/higher at lower levels, it may indicate that the room is too noisy for tuning, or that the microphone is clipping and AUDIO\_MGR\_MIC\_GAIN needs to be reduced.

If the distortion spectrum shape is similar across output levels, it indicates low distortion from the loudspeaker and housing. In this case, non-linear echoes are likely to have a small effect on echo cancellation.

---

**Note:** The XVF3800 provides an estimate of the current RT60 value of its environment. This is obtained via the AEC\_RT60 command.

---

It is also important to minimise/eliminate any path changes in the environment during non-linear tuning, such

---

as movement of people or objects. This tuning step is very deliberately placed after any gain or pre-processing adjustments have been made. Any changes to the device's gain structure, including changing any filtering, will require retuning of the non-linear model.

The tuning process should be run two or three times, and the results compared. If the plots are significantly different, this implies that non-linearities within the system are changing with time. This can indicate that the coupling between the loudspeaker and the microphones is varying over time, that there is time-dependent noise in the system, or that the external environment is changing with time (e.g. not totally silent).

#### **4.2.10.2 Tuning Setup for Non Linear model**

This tuning process is somewhat lengthy, and so a set of files and associated training script have been provided for this tuning step. The process differs slightly depending on whether the host device can play audio directly through the device (as in [Fig. 4.8](#)) or whether a 3rd computer is required (as in [Fig. 4.9](#)).

Local Device

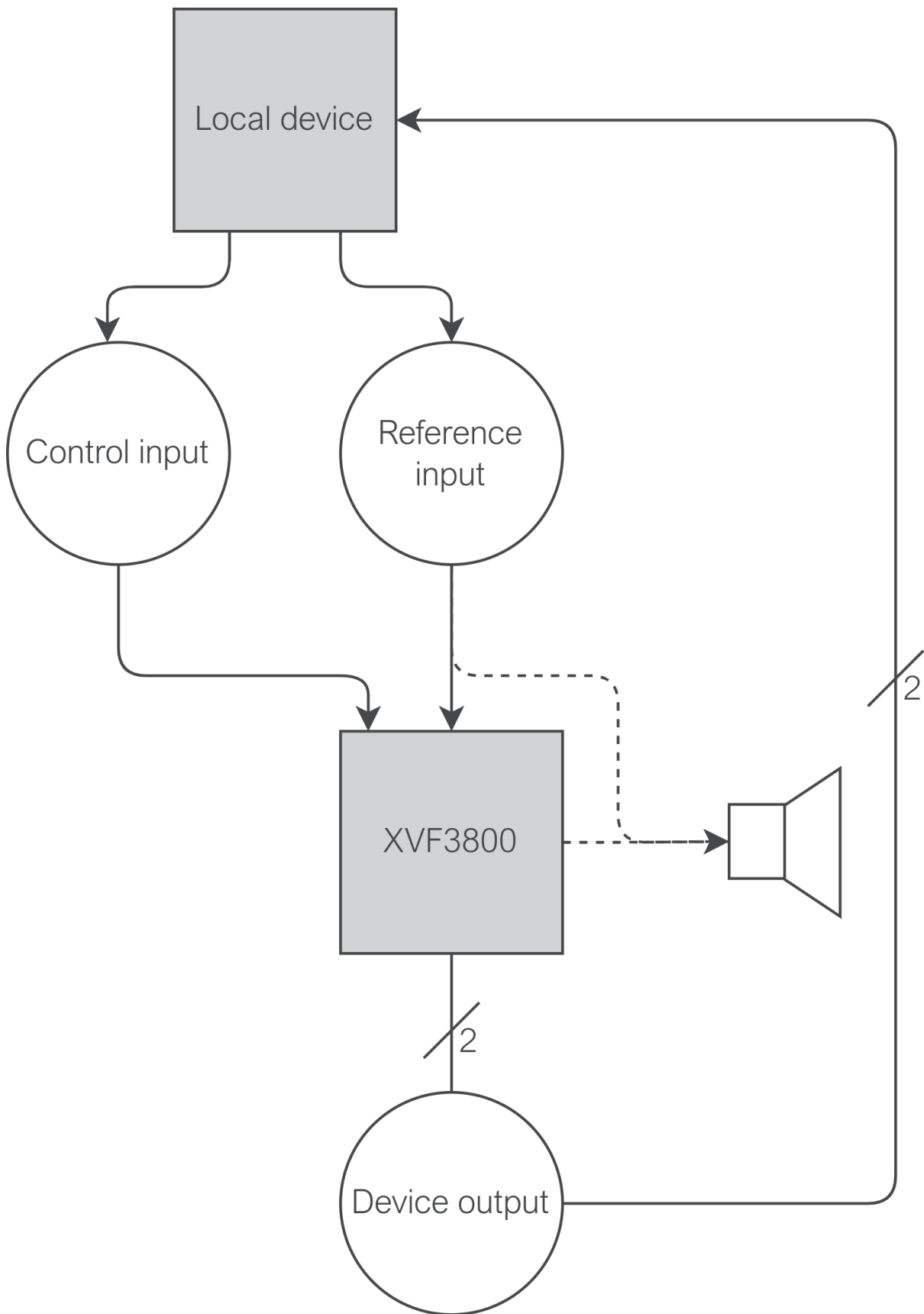

Fig. 4.8: Top-level diagram of a system where the audio host and control host are the same device



---

For this route, it is assumed that the host device is also the device that is providing audio to the XVF3800, through e.g. an I<sup>2</sup>S interface for the XVF3800 INT-Device variant or USB interface for the XVF3800 UA device. Via `xvf_tools.py`, it is possible to run the command `nl_model_training`, which executes all the necessary steps to train the non-linear model. Run the command `nl_model_training` as:

```
python3 xvf_tools.py nl_model_training <host_app> [--protocol {i2c,spi,usb}]
```

where `<host_app>` is the path to the `xvf_host` file, this can be an absolute path or a path relative to the current working directory.

This will generate an output file with the default name of `nlmodel_buffer_override.bin.r16.c40`. Copy this file to `sources/app_xvf3800/nl_model_gen/nlmodel_bin` and rerun the build process to generate a binary with this non-linear model set as default. A different output file can be selected by using the optional arguments `--output` and `--output_dir`. Refer to the docstring for this script for further guidance.

Remote Device

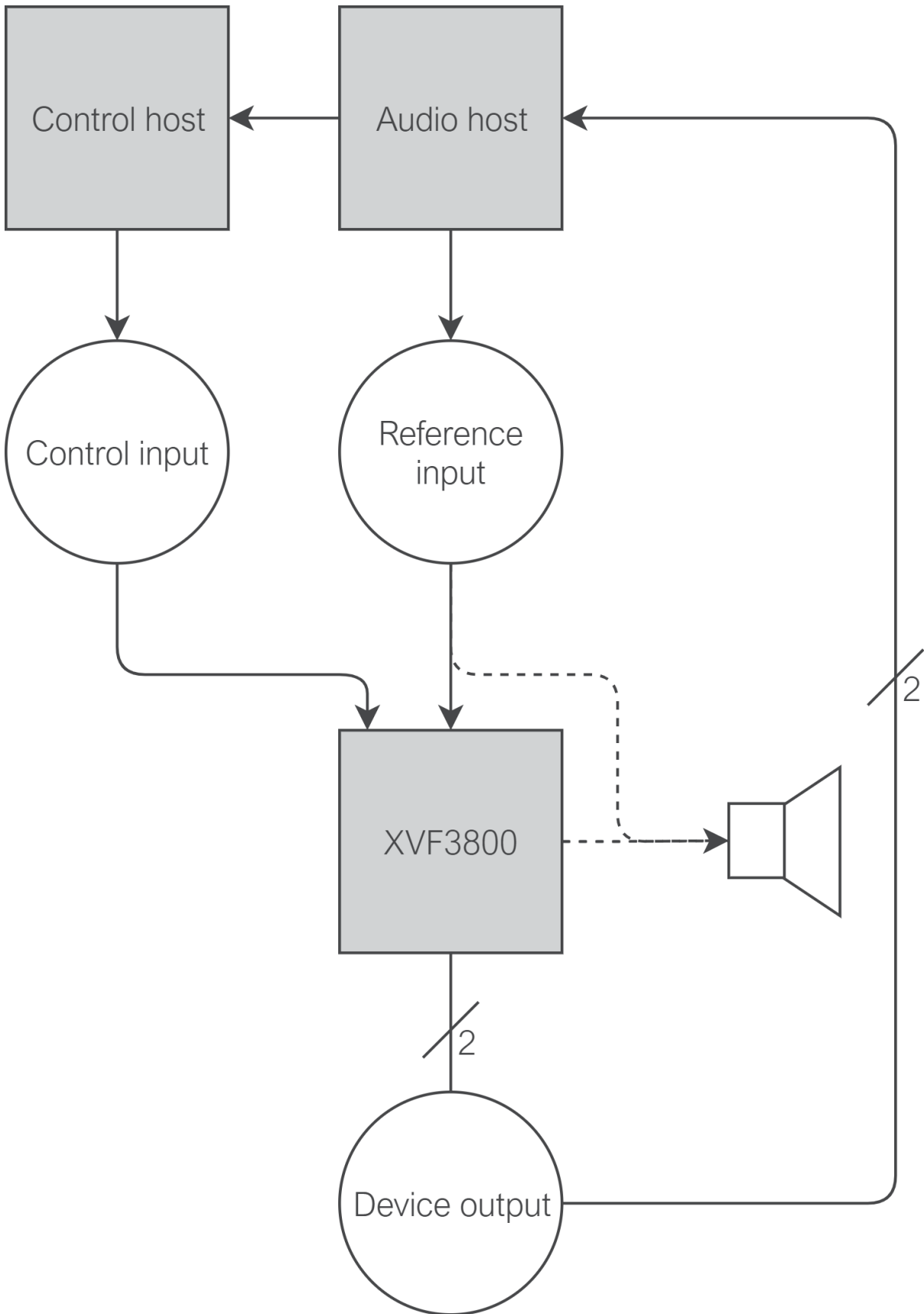

Fig. 4.9: Top-level diagram of a system where the audio host and control host are separate devices

---

For this route, it is assumed that a 3rd device is acting as the audio source (here termed the “audio host”). Therefore, to issue control commands, it is necessary to remotely connect to the “control host” (assumed to be a Raspberry Pi) over SSH. This can be done using the command `remote_nl_model_training` from `xvf_tools.py`. Locate the host application binaries on the audio host; these should be located at `host_v<version>/rpi` in the release package. Ensure that the audio host has passwordless access to the control host over SSH; this may be achieved by generating an SSH key pair and adding the public key to `~/.ssh/authorized_keys` on the control host.

This script requires that the audio host have an installation of `sox` in its path, as well as Python3 with `matplotlib` and `asyncssh` installed via Pip. Ensure that the default loudspeaker and microphone on the audio host are set as the device to be tuned.

From the audio host, run the script as:

```
python3 xvf_tools.py remote_nl_model_training <control host IP address> <host application binary  
↳path on the audio host>
```

Once the script has run, locate the generated `nlmodel_buffer_override.bin.r16.c40` and corresponding plot in the `src.autogen` directory. Copy this file to `sources/app_xvf3800/nl_model_gen/nlmodel_bin` and rerun the build process to generate a binary with this non-linear model set as default. A different output file can be selected by using the optional arguments `--output` and `--output_dir`. Refer to the docstring for this script for further guidance.

### Support for multiple products

The XVF3800 allows to have different `nlmodel` binary files for different build configurations. If the users have multiple `.bin.r16.c40` files, it can associate them to a specific build configuration by overwriting the CMake variable `NL_MODEL_BIN`, for example if a file `nlmodel_buffer_new_override.bin.r16.c40` must be included, the following line must be added in `sources/app_xvf3800/CMakeLists.txt`:

```
set(NL_MODEL_BIN nlmodel_buffer_new_override.bin.r16.c40)
```

## 4.2.11 Echo Suppression

With the non-linear model trained, we are now in a position to balance echo suppression against speech distortion. Five tuning parameters are relevant for this section:

- `PP_DTSENSITIVE`: This parameter sets a balance between double-talk performance and echo suppression.
- `PP_ECHOONOFF`: This parameter sets whether echo suppression is enabled or disabled overall.
- `PP_NLATTENONOFF`: This parameter sets whether non-linear echo suppression is enabled or disabled.
- `PP_GAMMA_E`: This parameter adjusts the oversubtraction factor for direct and early echo suppression.
- `PP_GAMMA_ENL`: This parameter adjusts the oversubtraction factor for non-linear echo suppression.
- `PP_GAMMA_ETAIL`: This parameter adjusts the oversubtraction factor for echo tail suppression.

For the `PP_GAMMA_*` parameters, a value of 1.0 indicates that the device has correctly estimated and suppressed the respective echo classes from the output. Increasing these values increases the amount of suppression, and indicates that the device has underestimated the amount of echo in the outputs. It is unlikely for the device to overestimate the amount of echo, and so it is not advised to set these parameters to values below 1.0. A typical range for these parameters is between 1.0 and 1.4.

Increasing these parameters will always affect the quality of the speech signal. Attempt in the first instance to create as good an acoustic design as possible, with a linear loudspeaker, good quality microphones, and a maximally non-linear enclosure. This will reduce or eliminate the need to adjust these values, and will present a more performant device.

### 4.2.11.1 PP\_DTSENSITIVE

PP\_DTSENSITIVE allows some control over the balance struck between double-talk performance and echo suppression, including the use of an optional near-end speech detector. This is summarised in Fig. 4.10; as echo suppression increases, double-talk performance will tend to decrease as more near-end is suppressed.

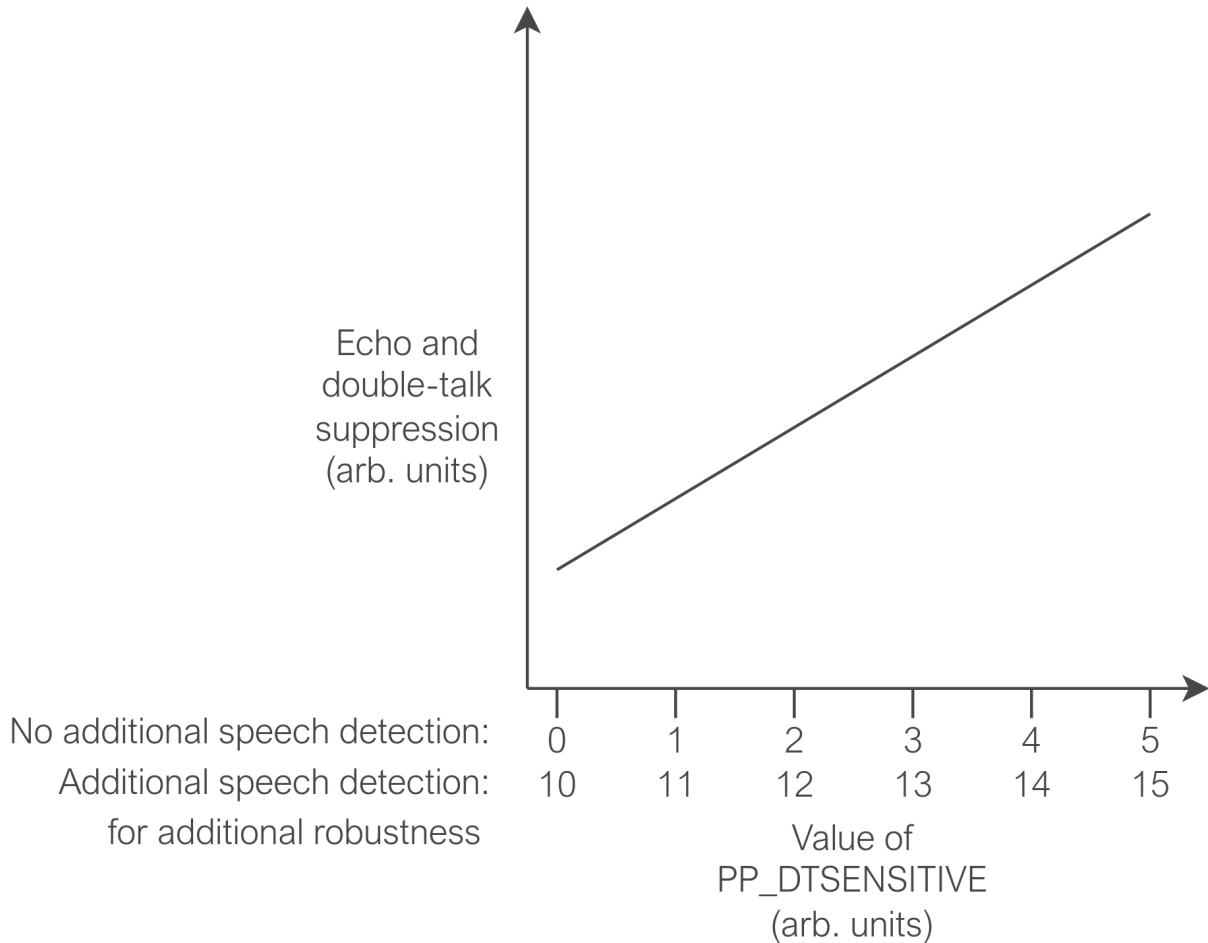

Fig. 4.10: Illustration of relationship between PP\_DTSENSITIVE value and echo suppression

The tuning process for this parameter is not straightforward. A recommended approach is to start with this parameter set to 0, and attempt to then tune the rest of the echo suppression parameters. If insufficient echo suppression is achieved before setting these parameters unacceptably high (above around 1.4), increase PP\_DTSENSITIVE and attempt to retune. If this results in unacceptable double-talk performance, lower PP\_DTSENSITIVE and attempt to retune. Find a balance between acceptable echo performance and double-talk performance by balancing settings for PP\_DTSENSITIVE and the PP\_GAMMA\_ parameters.

---

### 4.2.11.2 PP\_GAMMA\_E and PP\_GAMMA\_ENL

The objective of tuning these two parameters is the removal of echoes to pass e.g. Teams EQUEST and ECC specifications. Ensure that this tuning step takes place in an anechoic or mildly reverberant environment, with an RT60 less than 0.3 s.

Set the device as follows to output the autoselect beam in the left channel and the AEC residual signal for microphone 0 in the right channel:

```
(sudo) xvf_host(.exe) PP_AGCONOFF 0
(sudo) xvf_host(.exe) PP_MIN_NN 1.0
(sudo) xvf_host(.exe) PP_MIN_NS 1.0
(sudo) xvf_host(.exe) PP_GAMMA_E 1.0
(sudo) xvf_host(.exe) PP_GAMMA_ENL 1.0
(sudo) xvf_host(.exe) PP_GAMMA_ETAIL 1.0
(sudo) xvf_host(.exe) AUDIO_MGR_OP_L 6 3
(sudo) xvf_host(.exe) AUDIO_MGR_OP_R 7 0
```

Play through the reference input a representative signal, such as IEEE\_269-2010\_Male\_mono\_48\_kHz.wav. Allow the AEC to converge. After 30 seconds, play a representative near-end signal in addition to the far-end signal, to place the device into a representative double-talk scenario. Listen to the device's output. Starting with the default value of 1.0, adjust PP\_GAMMA\_E to make the trade-off between double-talk performance and echo suppression. Should the value of PP\_GAMMA\_E need to exceed around 1.4 to achieve acceptable performance, consider adjusting PP\_GAMMA\_ENL instead, especially if the echoes that remain in the AEC residual signal are of a non-linear nature.

To identify the nature of the echoes that remain, listen to the AEC residual signal and categorise the residual echoes as follows:

- Linear residual echoes: Echoes can be understood at a low level but do not sound distorted and do not sound reverberated. Controlled by PP\_GAMMA\_E.
- Tail echoes: Echoes sound reverberated, with no direct component. This will sound like indistinct reverb, but with no clear original source. Controlled by PP\_GAMMA\_ETAIL.
- Non-linear echoes: Echoes sounds very distorted, with no discernable e.g. speech content. Controlled by PP\_GAMMA\_ENL.

Note however that echo suppression is applied after the point where the AEC residual signals are tapped, and so changes to the PP\_GAMMA\_ parameters will not be reflected in the AEC residual signals. These signals are useful therefore for categorising the kinds of echo present, but the device's output should be used to observe qualitative changes in echo suppression.

### 4.2.11.3 PP\_GAMMA\_ETAIL

To tune this parameter, repeat the above procedure in a moderately reverberant room (with an RT60 between 0.3 and 0.9s). Clear tail echoes should be observed in the residual signal, and these tail echoes should be improved by adjustment of PP\_GAMMA\_ETAIL. Adjust this parameter, making a trade-off between double-talk performance and echo suppression.

---

## 4.2.12 Noise Suppression

Two parameters control suppression of stationary and non-stationary noise in the device output: `PP_MIN_NS` and `PP_MIN_NN` respectively. These parameters take values between 0 and 1, representing the multiplicative attenuation of these two noise sources. For example, `PP_MIN_NS` is set to 0.15 by default, representing a roughly 15 dB attenuation of stationary noise in the device output. It is recommended that `PP_MIN_NN` is set by default to 0.51 or higher, representing at most a 6 dB attenuation of non-stationary noise in the device output. Reducing this value further may have significant impact on near-end speech quality, especially in reverberant environments.

To tune these parameters, set the device as follows:

```
(sudo) xvf_host(.exe) PP_AGCNOFF 0
(sudo) xvf_host(.exe) PP_MIN_NS 0.15
(sudo) xvf_host(.exe) PP_MIN_NN 0.51
(sudo) xvf_host(.exe) AUDIO_MGR_OP_L 6 3
(sudo) xvf_host(.exe) AUDIO_MGR_OP_R 0 0
```

Play a representative near-end signal, such as `IEEE_269-2010_Male_mono_48_kHz.wav`. Subjectively evaluate the device output, first noting the presence of stationary noise. Reduce `PP_MIN_NS` to suppress this noise further. Reducing this parameter may introduce or increase distortion in near-end speech; ensure that a balance is struck between speech quality and stationary noise suppression. Note next the presence of non-stationary noise. Reduce `PP_MIN_NN` to suppress this noise further. As with `PP_MIN_NS`, reducing this parameter may introduce distortion in near-end speech, particularly in reverberant environments. Ensure that an appropriate balance is struck between speech quality and non-stationary noise suppression. Reducing the value of `PP_MIN_NN` to 0.5 or below will trigger additional non-stationary noise suppression.

## 4.2.13 ATTNS

The ATTNS parameters (`PP_ATTNS_MODE`, `PP_ATTNS_NOMINAL`, and `PP_ATTNS_SLOPE`) control an additional reduction in AGC gain during non-speech periods. Collectively, they attempt to combat an undesirable side-effect of the use of an AGC - the tendency to noticeably amplify noise in non-speech periods when the near-end speech signal is quiet. The Zoom Rooms specification test 7.4.3 (as of writing, last issued in October 2019) sets limits on how amplified this non-speech noise may be when the AGC is at a high gain compared to the noise level when the AGC is at a low gain. Therefore, attenuating noise at a greater strength when the AGC is at a high gain may reduce this noise and achieve better performance in these tests.

The overall behaviour of the ATTNS may be selected with the `PP_ATTNS_MODE` parameter, which both functions as a specifier of whether the ATTNS is in use and whether bias is applied against selecting beams with high noise as the autoselected beam.

- 0 - The ATTNS is off
- 1,2 - The ATTNS is on

---

**Note:** Setting ATTNS mode to 1 and 2 has the same effect.

---

When the ATTNS is on, `PP_ATTNS_NOMINAL` and `PP_ATTNS_SLOPE` control the additional attenuation proportional to:

$$\text{ATTNS\_NOMINAL} * \left( \frac{\text{AGCGAIN\_INIT}}{\text{AGCGAIN\_CURRENT}} \right)^{\text{ATTNS\_SLOPE}}$$

where `AGCGAIN_INIT` is the value of `PP_AGC_GAIN` set as the default value at initialisation, and `AGCGAIN_CURRENT` is the current value of `PP_AGC_GAIN`. Because of this module's relationship with the current

---

value of PP\_AGC\_GAIN, this module has no effect when PP\_AGC\_NOFF is set to 0.

Because both the Teams v4 and Zoom Rooms specifications specify this suppression as a ratio between the noise at a nominal speech level and the noise at a low speech level, it may be required to tune both of these parameters in parallel; changing one may have an effect on the required value for the other, and vice-versa.

To tune these parameters, ensure that PP\_AGC\_GAIN and PP\_AGC\_MAX\_GAIN are tuned correctly, then perform the following:

#### 4.2.13.1 ATTNS\_NOMINAL

Issue the following to set appropriate default values for this tuning step:

```
(sudo) xvf_host(.exe) PP_AGC_NOFF 1
(sudo) xvf_host(.exe) PP_ATTNS_MODE 1
(sudo) xvf_host(.exe) PP_ATTNS_NOMINAL 1.0
(sudo) xvf_host(.exe) PP_ATTNS_SLOPE 0.0
```

Play a representative near-end signal at a nominal level, such as the ITU P.501 7.3.2 reference signal FB\_male\_female\_single-talk\_seq.wav. This signal can be found in the Speech Signals/Test\_Signals-Clause 7/Speech Test Signals Clause 7.3 & 7.4/English\_FB\_clause\_7.3/ directory of the ITU P.501 download package.

Setting ATTNS\_NOMINAL > 1 should provide more noise suppression during silence. With a particular specification in mind, increase this value until desired/specified noise suppression is achieved during the test conditions. For example, this could be done by monitoring average A-weighted noise during the period 1s after the end of a sentence in the reference signal and ensuring that it is within satisfactory bounds. This is usually specified as a ratio between this value and the averaged value obtained with the near-end signal at a range of low levels.

#### 4.2.13.2 ATTNS\_SLOPE

Issue the following to set appropriate default values for this tuning step:

```
(sudo) xvf_host(.exe) PP_AGC_NOFF 1
(sudo) xvf_host(.exe) PP_ATTNS_MODE 1
(sudo) xvf_host(.exe) PP_ATTNS_NOMINAL <default found in previous step>
(sudo) xvf_host(.exe) PP_ATTNS_SLOPE 1.0
```

Play a representative near-end signal at a nominal level, such as the ITU P.501 7.3.2 reference signal FB\_male\_female\_single-talk\_seq.wav. Setting ATTNS\_SLOPE > 1.0 provides additional noise suppression during silence, proportional to an increased AGC gain. With a particular specification in mind, increase this value until desired/specified noise suppression is achieved during the test conditions. For example, this could be done by monitoring average A-weighted noise during the period 1 second after the end of a sentence in the reference signal and ensuring that it is within satisfactory bounds; this is usually specified as a ratio between this value and the averaged value obtained with the near-end signal at a range of low levels.

---

## 4.2.14 Path Change Detection

The XVF3800 provides a facility to detect significant path changes in the device's environment such as handling the device and moving to a different location using a module called the Path Change Detector (PCD). If a path change is detected, heavy near-end suppression during far-end activity is applied in order to allow the AEC time to reconverge to its new environment. If the device incorporating the XVF3800 is not intended for a mobile application (for example, a wall-mounted sound bar), then detection of path changes is not necessary.

The PCD may be tuned using the `AEC_PCD_COUPLINGI`, `AEC_PCD_MINTHR`, and `AEC_PCD_MAXTHR` parameters.

`AEC_PCD_COUPLINGI` controls the rate of detection of a path change, and takes a value between 0 and 1. Setting this to a low value encourages fast detection of path changes at the increasing risk of false positives during double-talk. Setting this to a high value slows detection of path changes (and increases the detection threshold, meaning some small changes may be missed) but reduces the risk of false positives in double-talk. Setting this parameter to a value outside of the range 0 to 1 will disable the PCD. Tuning of this parameter is necessarily very situation- and product-dependent. Monitoring of the `AEC_AECPATHCHANGE` parameter can allow insight into whether a path change has been detected; reading a 1 value implies that a path change has recently been detected and that the device output is currently heavily suppressed during far-end activity. This parameter will reset to 0 after the AEC has reconverged.

`AEC_PCD_MINTHR` and `AEC_PCDP_MAXTHR` are used to set sensitivity thresholds, and their use depends on the overall Echo Return Loss Estimate (ERLE) of the device. For devices with a high ERLE (implying a high ratio between the provided reference signal and the resultant AEC residual, and therefore high cancellation), use `AEC_PCD_MINTHR` to limit the lower bound. Decreasing this value from its default of 0.02 will increase the sensitivity of the PCD. For devices with a low ERLE, use `AEC_PCD_MAXTHR` to limit the upper bound. Decrease this value from its default of 0.2 to increase the sensitivity of the PCD.

## 4.2.15 Output equalization

The XVF3800 has an equalizer that can be used to adjust the output frequency response, should it not meet the limits in a Teams/Zoom spec. This may be needed to compensate for the frequency response of the microphones and their housing. The equalizer is applied in the frequency domain before the AGC. `xvf_tools.py` provides the command `ploteq` to generate the coefficients. To run the script, run the following command:

```
python3 xvf_tools.py ploteq
```

The script produces a GUI shown in the picture below.



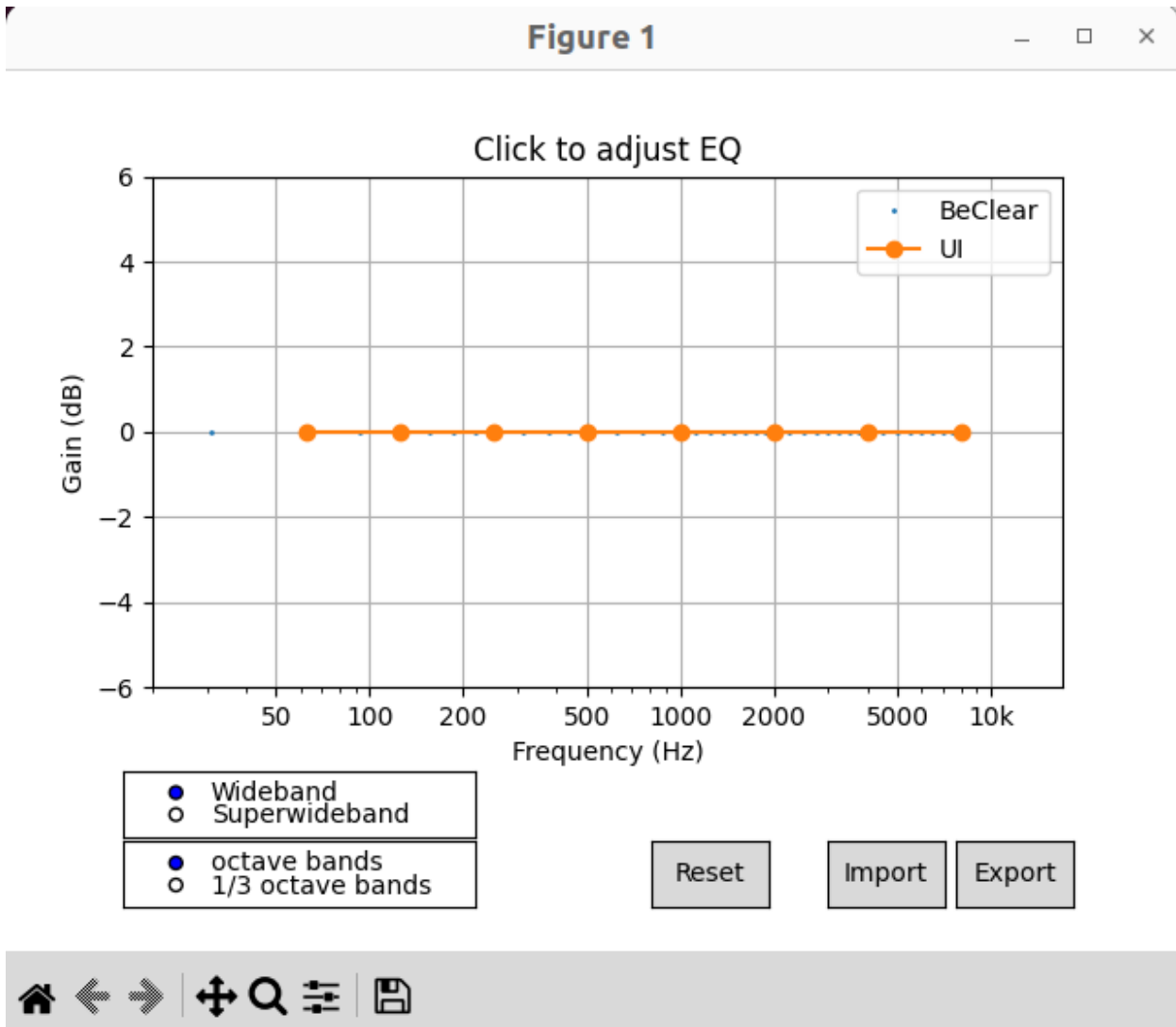

The user must first select in the lower left corner:

- the band appropriate for the device: wideband or superwideband
- the desired resolution: “octave bands” gives an 8 band equalizer with control points at one octave intervals [62.5, 125, 250, 500, 1000, 2000, 4000, 8000], while “1/3 octave bands” give finer resolution, with a 22 band equalizer with control points at 1/3 octave intervals.

The user can click on the GUI to update the frequency gains and to achieve the desired filter. The coefficients can be exported using the *Export* command in the lower right corner.

When the file with the desired coefficients is ready, it can be written to the device using the command:

```
(sudo) xvf_host(.exe) --set-eq-filter eq.bin
```

where *eq.bin* is the file exported by the *ploteq* command.

The user can override the default equalization filter included in the build. To do this:

- rename the *eq.bin* file generated above as *eq\_filter\_override.bin*
- copy it to folder *sources/app\_xvf3800/eq\_filter\_gen/eq\_filter\_bin/*
- rerun the build process to create a binary with the new equalization filter set as default.

The filter can be read using the command:

```
(sudo) xvf_host(.exe) --get-eq-filter eq.bin
```

and it can be visualised using the *Import* command in the GUI of the *ploteq* command.

## 4.3 Changing Default Parameter Values

The default parameters set at start-up are loaded from the file `defaults.c` in `sources/app_xvf3800/src/default_params`. In this file the values are included from some header files auto-generated at compile time. The values used in `defaults.c` must be updated using the YAML files stored in `sources/app_xvf3800/autogeneration/yaml_files/settings_and_defaults/`. The XVF3800 supports separate default values for different products. In the `sources/app_xvf3800/autogeneration/yaml_files/settings_and_defaults/` there is a subfolder for each product specifier, for example the default values for the XK-VOICE-SQ66 development kit are stored in the product subfolder.

---

**Note:** Any default value set outside the YAML files will be overwritten at compile time.

---

In the product directory five files used to generate `defaults.c` are present:

- `mic_geometries.yaml`
- `control_param_values.yaml`
- `gpi_config.yaml`
- `gpo_config.yaml`
- `usb_param_values.yaml`

**Warning:** All the parameters in the files above must be set; failure to do this can lead to unexpected behaviour of the device, such as uninitialized start-up values.

---

**Note:** `PP_MGSCALE` provides three values when queried through the host application, but only requires two to be set here - **max** and **min**.

---

`mic_geometries.yaml` contains the coordinates for each of the 4 mics for both the linear and square/rectangular geometries. An example of the values is below:

```
LINEAR_GEOMETRY:
- MIC0: ( -0.04995f,    0.00f,    0.00f )
- MIC1: ( -0.01665f,    0.00f,    0.00f )
- MIC2: (  0.01665f,    0.00f,    0.00f )
- MIC3: (  0.04995f,    0.00f,    0.00f )
SQUARECULAR_GEOMETRY:
- MIC0: (  0.0333f,    -0.0333f,    0.00f )
- MIC1: (  0.0333f,    0.0333f,    0.00f )
- MIC2: ( -0.0333f,    0.0333f,    0.00f )
- MIC3: ( -0.0333f,    -0.0333f,    0.00f )
```

The user must update the values to match the geometry used in their target application. The default configurations shown above are those supported by the XK-VOICE-SQ66 development kit.

`control_param_values.yaml` lists all the control parameters which can be configured. An example of a parameter with a default value is below:

```
PP_RESID:
- cmd: PP_AGCONOFF
  default_value: on
```

The parameters in the file are organized into arrays, and each array contains all the parameters related to a particular control resource ID. The parameter name is stored in the `cmd` key and the default value in the `default_value` key. In the example above, the default value of the parameter `PP_AGCONOFF` belonging to the `PP_RESID` is `on`. The number of values and type of each parameter may vary from command to command. It is advised to look up the command information in the tables in the [Control Commands Appendix](#) and to follow the format of the original default values in order to set the values properly.

`gpi_config.yaml` stores all the settings of the GPI pins. The XVF3800 has 2 configurable GPI pins and the following parameters can be modified:

- `active_level`: 0 for low and 1 for high
- `event_config`: four types of events are supported:
  - `EdgeNone`: no event is detected on either edge
  - `EdgeFalling`: an event is detected on the falling edge (high to low transition)
  - `EdgeRising`: an event is detected on the rising edge (low to high transition)
  - `EdgeBoth`: one event is detected on the rising edge and one on the falling edge

The default configurations of the GPI pins are below:

```
# Exactly GPIO_NUM_INPUT_PINS pins should be defined here
```

```
PIN0:
  active_level: 1
  event_config: EdgeNone
PIN1:
  active_level: 1
  event_config: EdgeNone
```

`gpo_config.yaml` lists the settings of all the GPO pins and ports. The XVF3800 device has one 8-bit port designated for GPO. Only five of the eight are pinned out, and three pins are required for the device to operate normally, leaving the remaining two pins available for user modification. These pins are number 6 and 7, and they are used to control the LEDs in the default firmware.

In the file each port must be listed; the XVF3800 only implements `PORT0`. For each port an array of eight pins must be defined and each pin has the following configurable settings:

- `pin_number`: this value shouldn't be modified
- `active_level`: 0 for low and 1 for high
- `output_duty_percent`: Pulse-width modulation (PWM) duty cycle specified as a percentage
- `flash_serial_mask`: serial flash mask where each bit specifies the GPO pin state for a 100 ms time period interval

The default configurations of the GPO port and pins are below:

```
PORT0:
# UNUSED: NOT PINNED OUT
- pin_number: 0
  active_level: 1
  output_duty_percent: 0
  flash_serial_mask: 0xFFFFFFFF
# UNUSED: NOT PINNED OUT
- pin_number: 1
  active_level: 1
  output_duty_percent: 0
```

(continues on next page)

```

flash_serial_mask: 0xFFFFFFFF
# UNUSED: NOT PINNED OUT
- pin_number: 2
  active_level: 1
  output_duty_percent: 0
  flash_serial_mask: 0xFFFFFFFF
# GPO_DAC_RST_N_PIN
- pin_number: 3
  active_level: 1
  output_duty_percent: 100
  flash_serial_mask: 0xFFFFFFFF
# GPO_SQ_nLIN_PIN
- pin_number: 4
  active_level: 1
  output_duty_percent: 0
  flash_serial_mask: 0xFFFFFFFF
# GPO_INT_N_PIN
- pin_number: 5
  active_level: 1
  output_duty_percent: 100
  flash_serial_mask: 0xFFFFFFFF
# GPO_LED_RED_PIN
- pin_number: 6
  active_level: 0
  output_duty_percent: 0
  flash_serial_mask: 0xFFFFFFFF
# GPO_LED_GREEN_PIN
- pin_number: 7
  active_level: 0
  output_duty_percent: 0
  flash_serial_mask: 0xFFFFFFFF

```

usb\_param\_values.yaml lists the settings of the USB port.

The default configuration of the USB port is shown below:

```

VENDOR_ID: 0x20B1
PRODUCT_ID_IO_16KHZ: 0x4F01
PRODUCT_ID_IO_32KHZ: 0x0000
PRODUCT_ID_IO_48KHZ: 0x4F00
MANUFACTURER_STR: "XMOS"
PRODUCT_STR: "XVF3800 Voice Processor"
SERIAL_NUMBER_STR: "000000"
CONTROL_INTERFACE_STR: "XMOS Control"
HID_INTERFACE_STR: "XMOS HID"
DFU_FACTORY_INTERFACE_STR: "XMOS DFU Factory"
DFU_UPGRADE_INTERFACE_STR: "XMOS DFU Upgrade"
DEFAULT_BIT_DEPTH_IN: "16"
DEFAULT_BIT_DEPTH_OUT: "16"

```

**Note:** When the default parameters are changed, it is necessary to rebuild the application and reload onto the XVF3800 as described in the following section. See [Building an Executable](#).

**Warning:** The process to rebuild the application does not check each parameter's value to ensure that it falls within its valid range. A change to a parameter value that falls outside of its valid range may result in undefined behaviour.

The XVF3800 build system supports multiple sets of default values. If a new product with different default

---

values must be built, do the following:

1. Create a new folder in `sources/app_xvf3800/autogeneration/yaml_files/settings_and_defaults/`, for example `new_product`
2. Copy the YAML files in `sources/app_xvf3800/autogeneration/yaml_files/settings_and_defaults/product` into the new folder
3. Update the values in the new YAML files
4. Add or modify a build configuration as described in Adding or Modifying Build Configurations section of the Programming Guide
5. Overwrite the CMake variable `PRODUCT_DEFAULT_SPECIFIER`, for example by adding in `sources/app_xvf3800/CMakeLists.txt` the following:

```
set(PRODUCT_DEFAULT_SPECIFIER new_product)
```

# 5 Building the Application Firmware

---

## 5.1 Introduction

The XVF3800 comprises a specialised xcore.ai processor and a firmware executable. A set of firmware images is provided in the binary release package which are configured to run correctly on the XK-VOICE-SQ66 development kit. However, when using the XVF3800 in a product design it is normally necessary to modify the firmware to match the hardware and to configure a number of settings. This is achieved by modification of the configuration files supplied as source code and rebuilding the modified code to create a new firmware image.

Instructions on configuring the firmware is included in the *Tuning the application* section.

This section explains how to build the XVF3800 application from files in the source release package.

## 5.2 Prerequisites

The XVF3800 source code can be build on Windows, macOS and Linux platforms.

---

**Note:** An active internet connection is required as part of the process as the build scripts download additional packages to configure the environment.

---

The XVF3800 build procedure requires that a set of 3rd Party software packages, listed below, are installed on a development computer before attempting to build firmware for the XVF3800.

### 5.2.1 Python3

A standard installation of Python version 3.10 or higher should be present on the development computer. This is available by default on some platforms, but if required it can be installed from <https://www.python.org/downloads/>.

The pip3 package manager included in the standard python configuration is used to install some tools and python is required to run some setup and tuning tools.

### 5.2.2 XMOS tools

XTC Tools 15.3.x : This is the XMOS toolchain which allows users to compile, link, deploy and debug applications on all XMOS processors.

The XTC Tools can be downloaded from <https://www.xmos.com/software-tools/> and installed on a development computer following the instructions in the <https://www.xmos.com/view/Tools-15-Documentation>. XTC tools can run on Windows, macOS and Linux platforms.

---

## 5.2.3 Build Tools

CMake >= version 3.21.0 : CMake is a build tool for managing application compilation.

The CMake tool package can be installed following the instructions for your specific OS platform at <https://cmake.org/install/>.

The recommended make tools depend on the development platform:

(Linux and macOS): GNU Make - Available through your system package manager.

Ninja (Windows): Ninja - Follow install instructions at <https://ninja-build.org/> or on windows install with winget by running the following commands in PowerShell:

```
# Install
winget install Ninja-build.ninja
# Reload user Path
$env:Path=[System.Environment]::GetEnvironmentVariable("Path","User")
```

## 5.3 XVF3800 Release Package

The XVF3800 firmware is supplied in two different release packages which are distributed as ZIP archive files with the following contents:

1. Binary release - a set of pre-compiled images that will run on the XK-VOICE-SQ66 development kit
2. Source release - Source code and libraries to allow customisation of the XVF3800

This section describes how to use the second package.

Release packages for XVF3800 can be obtained from the XVF3800 [developer page](#) or from your XMOS representative.

Load the ZIP archive onto your development platform and expand the archive into a convenient directory. It contains the release notes and a TAR file. On Linux or macOS, expand the TAR file using:

```
tar -xvf xvf3800_source_[date]_[time].tar
```

where [date] is the build date in yymmdd format and [time] is the build time in hhmmss format.

On Windows, expand the TAR file using the 7-zip utility. This utility is freely available in the Microsoft Store. Open a file browser and navigate to the folder containing xvf3800\_source\_[date]\_[time].tar. Right click on this file. If necessary, select 'Show more options'. Highlight '7-zip' and select one of the 'Extract' options. If necessary, press the 'Close' button upon completion.

The contents of the source release package are shown below:

```
.
  CHANGELOG.rst    <- list of changes of current and past releases
  LICENSE.rst     <- license file
  precompiled     <- directory containing the precompiled libraries
  README.md       <- readme file
  sources         <- source files necessary to build XVF38xx applications
```

The user modifiable code is found in the sources/app\_xvf3800 directory.

### 5.3.1 Standard Configurations

The XVF3800 release package contains a set of standard build configurations that will suit the majority of use cases for the XVF3800 device. The table below lists the key configuration parameters.

Table 5.1: Build-time combinable parameters

Parameter	Options	Abbreviation	Notes
Device configuration	INT-Device USB	-intdev -ua	
I <sup>2</sup> S LR clock rate	16000 48000	-lr16 -lr48	Select sampling rate for I <sup>2</sup> S interface; ignored for UA configurations.
USB IN/OUT sample rate	16000 48000	-io16 -io48	Only valid in UA configuration; ignored for INT configurations.
Microphone geometry	Linear Square or circular	-lin -sqr	Selects microphone configuration on XK-VOICE-SQ66 board
Control protocol	I <sup>2</sup> C SPI	-i2c -spi	Select control protocol for INT configurations; ignored for UA configurations, as they always use USB as control interface.
Audio MCLK	Use external MCLK signal	-extmclk	Only valid on INT-Device configuration. Should be omitted if an external MCLK is not used.

### 5.3.2 Image Names

The XVF3800 built image names comprise the parameter abbreviations listed above in a set order:

```
<device config>-<sample rate>-<mic geometry>-<control protocol>[-extra-options]
```

where *<control protocol>* is not set for UA, as it always uses USB, and *-extra-options* can be *-extmclk*, *-io-exp* and *-spatial*.

Examples:

- `-ua-io48-lin`
- `-intdev-lr48-sqr-i2c`
- `-intdev-lr48-lin-spi-extmclk`

More information about the supported build configurations can be found in the tables [Table 2.1](#) and [Table 2.2](#).



---

## 5.4 Build Process

### 5.4.1 Set up the environment

---

**Note:** The software packages in the *Prerequisites* section must be installed before starting this process.

---

To build the XVF3800 application, open a command-line terminal and ensure that the XMOS tools are configured in the environment. This can be checked by typing:

```
xcc --version
```

which should display the tools version information. If this does not happen please consult the *Configuring the command-line environment* section of <https://www.xmos.com/software-tools/> at <https://www.xmos.com/view/Tools-15-Documentation>.

### 5.4.2 Configure the build system

The build process comprises of two phases - the first phase sets up the build environment and downloads key components while the second phase builds a specific executable. Configuration is only required to be done once.

To set up the environment change directory to the `sources` directory of the release package and install the required Python3 packages:

```
cd sources
```

```
pip3 install -r requirements_build.txt
```

Then configure the build. This step can take several minutes. The preset to use depends on the host computer.

```
# Windows
cmake --preset=rel_app_xvf3800_windows
# Not Windows
cmake --preset=rel_app_xvf3800
```

---

**Note:** On Windows the maximum file path length is 260 characters. If the build path exceeds this length, the build may fail. If a warning is displayed about the maximum file path, move the source code to a directory with a shorter path length.

---

When this is complete the XVF3800 build system has been configured.

---

### 5.4.3 Build an executable

The next phase is to build a specific executable. The release package contains a set of configurations that cover the main use case for the XVF3800 device.

To see the available build presets use:

```
cmake --build --list-presets
```

The naming scheme for these presets is defined in the [Standard Configurations](#) section above.

Select the preset you wish and start the build.

For example to build a 48 kHz USB configuration with a square microphone array is:

```
cmake --build --preset=ua-io48-sqr
```

The script will compile all the source file and when it completes the generated binary file is saved in the subdirectory `build`.

The required executable binary will be named `application_xvf3800_ua-<build options>.xe`. As an example the result of the build command above would be:

```
build/application_xvf3800_ua-io48-sqr.xe.
```

## 5.5 Installing the Executable Image

Two methods exist to install on the XVF3800 hardware the executable image created in the previous section, using the `xrun` and `xflash` tools that are supplied in the XTC Tools suite.

Both methods require a connection between a development computer and the XVF3800 via an XTAG4 debug adapter. Instructions to set up the XK-VOICE-SQ66 development kit can be found in the [Setting up the hardware](#) section of this guide.

### 5.5.1 Install Using `xrun`

The `xrun` tool loads the executable image into the XVF3800 RAM without storing it in the XVF3800 Flash ROM. It then starts the operation of the XVF3800 using this executable image. Using the example from above the required command is:

```
xrun application_xvf3800_ua-io48-sqr.xe
```

### 5.5.2 Install Using `xflash`

The `xflash` tool stores the executable image in the XVF3800 Flash ROM. A subsequent power-cycle loads the stored image into the XVF3800 RAM and starts its operation. Using the same example from above the required command is:

```
xflash application_xvf3800_ua-io48-sqr.xe
```

---

## 5.6 Using SPI Boot

### 5.6.1 Creating a SPI Boot File

To use the built `application_xvf3800_[...].xe` executable generated from the above process as a SPI boot image it is necessary to convert the `.xe` image into a `.bin` file that includes a bootloader.

The files required to build this `.bin` image can be found in the `sources/modules/fwkw_xvf/modules/boot_spi_slave` directory of the source release package.

**Warning:** This procedure requires the XTC tools to be installed on a development computer. It cannot be run on the Raspberry Pi host.

To create a SPI boot image change into the `sources` directory:

```
cd sources/
```

and then generate the binary image using the following command:

```
python3 xvf_tools.py generate_image <path/to/application_xvf3800_[...].xe>
```

An SPI bootable file `application_xvf3800_[...]_spi_boot.bin` will be created in the `build` subdirectory.

### 5.6.2 Using a SPI Boot File

#### 5.6.2.1 Safe SPI Booting

The SPI boot process is documented in the XVF3800 datasheet. An example python script is provided in the source release package which uses a Raspberry Pi to transfer the image and boot the XVF3800 device on an XK-VOICE-SQ66 development kit.

---

**Note:** The Raspberry Pi must be setup as described in the `setting up the hardware` section for this script to operate correctly.

---

The python script can be found in `sources/modules/fwkw_xvf/modules/boot_spi_slave/scripts` subdirectory. This script and the `_spi_boot.bin` image generated using the procedure described above should be copied onto the Raspberry Pi.

To boot the XVF3800 device the following command should be run from `sources`:

```
sudo python3 xvf_tools.py send_image_from_rpi <build/application_xvf3800_[...]_spi_boot.bin>
```

The example script will need to be modified, if this procedure is executed on other host systems.

---

**Note:** The Python script provided is designed to be simple and safe. It uses a conservative SPI clock (12.5 MHz) and large inter-block delays for all blocks.

---

### 5.6.2.2 Fast SPI booting

The SPI boot process is capable of running significantly faster (a few hundred milliseconds typically) through use of an optimized boot process. An example of a speed-optimized boot host utility can be found in the `sources/modules/fw_k_xvf/modules/boot_spi_slave/fast_send` subdirectory.

The maximum SPI clock speed can be up to 50 MHz depending on the signal integrity of your hardware. It has also been found that the Python SPI library incurs a latency of a few milliseconds after each 4 kB block has been transferred.

The XVF3800 device boot process has constraints that mean it needs a minimum inter-block delay to be applied at specific points throughout the boot process.

By taking into account these constraints and using a C language utility a much improved boot time may be achieved. The boot process requires inter-block delays at two stages as can be seen in [Fig. 5.1](#):

- A PLL settling delay after the tile[0] second stage bootloader has been received following the first 4 kB block. This delay may be as low as 1 millisecond.
- An inter-tile transfer delay after the tile[1] application image has been received and is sent from tile[0]. The block count for this will vary depending on the binary size. The delay value typically needs to be 5 ms but may be longer if the firmware has been modified or a significant amount of extra code has been added.

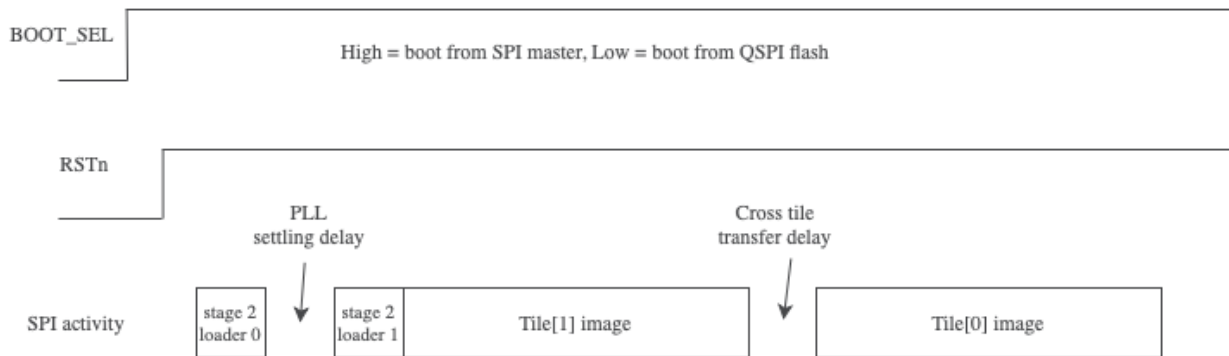

Fig. 5.1: Fast SPI boot time diagram

To determine the inter-tile transfer delay block number, please inspect the output from `generate_image.py`. For example, the following run indicates that the inter-tile transfer delay should be applied after the 103rd, 4 kB block has been sent:

```
-----  
3384 loader object bytes (includes header but not ROM size word)  
412780 image bytes  
443944 image bytes  
transfer_block_num: 103  
-----
```

To build the fast SPI boot example for the Raspberry Pi do the following:

```
cd sources/modules/fw_k_xvf/modules/boot_spi_slave/fast_send  
make
```

To run the fast SPI boot utility pass the SPI boot image file, SPI clock speed and `transfer_block_num` to the binary. For example:

```
./send_image ../build/application_xvf3800_[...>_spi_boot.bin 50000000 103
```

---

The default firmware flashes the green LED on the XK-VOICE-SQ66 development kit to indicate successful boot. If boot was not successful first try reducing the SPI clock speed and ensure that the `transfer_block_num` matches the generation stage output. To check the hardware is operational you may also wish to try the [Safe SPI Booting](#) stage first.

---

**Note:** The Raspberry Pi 4 has a bug in the `spidev` driver where the output of the SPI peripheral is left in a non-working state after a single boot. Running `sudo rmmmod spi_bcm2835 && sudo modprobe spi_bcm2835` after `send_image` has been found to work-around this.

---

## 6 Some Acoustic Design Guidelines

---

This chapter presents a brief guide to a number of introductory acoustic considerations that designers should take into account when integrating the XVF3800 into their end product.

It should be stressed that a more ideal acoustic design will result in fewer compromises needing to be made whilst configuring the XVF3800. Designers should invest time in the acoustic design of the end product in order to optimise the overall product performance.

Note that the requirements discussed here are only intended as general guidelines to help devise a more precise product specification. The actual specification will depend on the intended application. For example, even within a telecommunications application, a handset, personal speakerphone, or shared space speakerphone will each have very different technical specifications.

Additionally, many certification requirements have multiple available levels of certification. For example, Microsoft Teams Audio Requirements has a basic and a premium certification level, where the premium level features more stringent requirements. A similar situation with basic and premium criteria can be found in Amazon's certification requirements for voice services.

Therefore, this document will not cover all the different potential requirements or applications. These must be decided on a case-by-case basis to match with the intended application of the product with consideration to the desired certification requirements.

Instead, this document will cover the technical areas that should be considered when designing the product specification. Where numerical values are given, they should not be considered recommended or required, but instead are provided as a "ball-park" figure for context. These figures have been chosen based on a generic product design for a typical smart speaker or personal speakerphone which aims to pass the basic level of certification requirements.

### 6.1 Microphones

The XVF3800 requires 4 microphone inputs. These microphones may be omnidirectional; no additional benefit has been observed from the use of e.g. cardioid polar patterns.

Microphones chosen for a design should exhibit a signal-to-noise ratio (SNR) greater than 67 dB. This ensures a sufficiently low microphone self-noise, allowing a low enough noise floor for the XVF3800 to function effectively. Matched microphones are however not necessary. Total Harmonic Distortion (THD) should be less than 1%, although with modern MEMS microphones this is usually the case so long as the microphone is not operating near its acoustic overload point.

For compatibility with the XVF3800, microphones chosen should be digital MEMS microphones with a PDM output. These will be clocked at 3.072 MHz, with a decimation factor applied in firmware to generate the sampling rate used internally.

With loudspeakers operating at their loudest volume, microphones should not reach acoustic overload. At loudest loudspeaker volume, a headroom of 6 to 10 dB is a reasonable goal. It is important that the microphones are not driven into a non-linear response due to the volume of the loudspeakers in the end product. For far field voice a sensitivity of approximately -30 dBFS @ 94 dBSPL would be appropriate. For the SNR of 64 dB listed above, this would mean the noise floor is lower than -94 dBFS.

The XVF3800 supports both circular and linear microphone arrays. It is important to differentiate between "spacing" of the microphones and "aperture" of the array. The spacing is the distance between individual microphones whereas aperture is the outer limits of the array. The spacing is important for the high frequency limit. Make sure that  $d < \text{wavelength} / 2$  to avoid spatial aliasing, e.g., for a 3 cm spacing the high frequency limit is 5.7 kHz.

---

The aperture defines the low frequency limit based on the ability to measure a phase difference between the microphones, so when the wavelength is much larger than the array aperture, the phase (and signal) at each microphone is nearly identical and it's impossible to differentiate between the two signals.

There is not a hard limit in the way there is for high frequency; usually the low frequency limit is defined based on the beam width, which also varies with the number of microphones. As a rough rule of thumb, the array aperture should be at least 5% of the wavelength, i.e., for a 10 cm aperture the low frequency limit is 172 Hz.

However, regardless of the geometry chosen, at least 2 (and preferably more) of the microphones in the array should be approximately 10 cm apart. This is in order to ensure sufficient phase difference between microphones at lower frequencies to allow the AEC to function.

The frequency response should cover the desired voice band. For a wideband application, a response from 100 Hz to 10 kHz should be easily obtainable. A frequency mask can be defined to ensure flatness of the response, e.g.,  $\pm 2$  dB from 100 Hz to 6 kHz and  $\pm 4$  dB from 6 kHz to 10 kHz.

With zero input (i.e. a silent room), there should be low coherence between microphone signals - that is to say, the self-noise of the microphones chosen should not be correlated between microphones. If correlation is observed with zero input, this usually indicates that there exists some common-mode interference between the microphone signals. The presence of correlated noise has a negative effect on the performance of the XVF3800, and so this should be as minimal as possible. To estimate coherence between pairs of microphones at frequencies up to the Nyquist limit (which in this system will be 8 kHz), `xvf_tools.py` provides the command `coherence` to generate a plot similar to that shown in [Fig. 6.1](#), where the blue line shown is real data from two microphones in a silent room and the red line is a theoretical coherence plot between two perfect microphones measuring diffuse noise. This theoretical model is a  $\text{sinc}^2$  function with its maximum at DC and its first zero crossing at  $f$  given by  $f = c / 2d$ , where  $c$  is the speed of sound (in m/s) and  $d$  is the distance between microphones (in m). The script can be called using `xvf_tools.py` which is located in `sources`. The script can be run using the command:

```
python3 xvf_tools.py coherence <mic0_1.wav>
```

The signal `mic0_1.wav` should be a 2 channel, 16 kHz WAV file with two microphone signals, which should be captured in silence; to capture these signals using the XVF3800's output, issue:

```
(sudo) xvf_host(.exe) AUDIO_MGR_OP_L 1 0
(sudo) xvf_host(.exe) AUDIO_MGR_OP_R 1 1
```

Record 30 seconds of output from the device, and repeat for the other microphones:

```
(sudo) xvf_host(.exe) AUDIO_MGR_OP_L 1 2
(sudo) xvf_host(.exe) AUDIO_MGR_OP_R 1 3
```

Further information on the use of the host application to capture output can be found in [Using the Host Application](#) and documentation of this script may be found in its docstring.

For optimal algorithmic performance, the coherence between each possible pair of microphones should be less than 0.1. All possible pairs of microphones should be tested; this will result in a total of 6 plots. One example plot is shown in [Fig. 6.1](#), where the blue line is real data and the red line is a theoretical coherence between two perfect microphones recording diffuse noise.

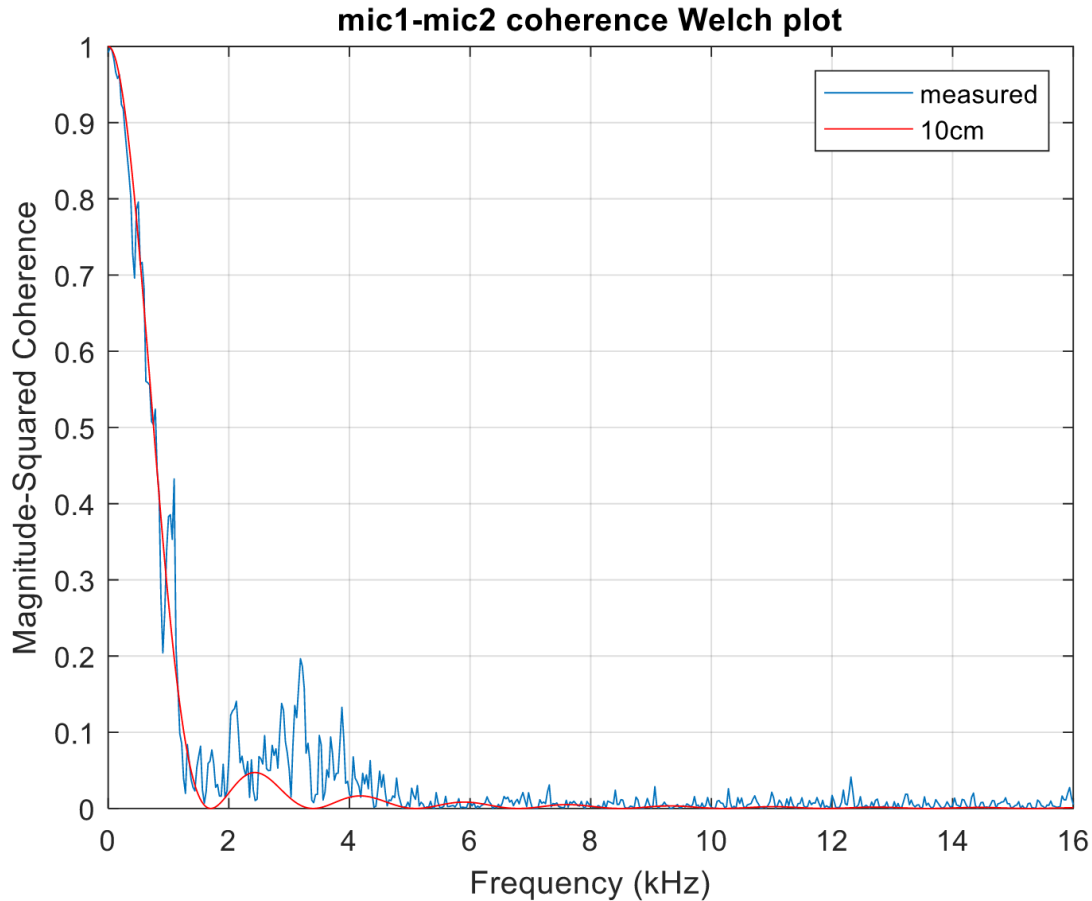

Fig. 6.1: Sample coherence plot between two microphones

## 6.2 Loudspeaker(s)

The loudspeaker, power amplifier and DAC are considered together as the playback path of the product. The frequency response of this assembly should cover the desired voice band, e.g., wideband should cover 250 Hz to 6.3 kHz. As mentioned in the microphone section, a mask can be defined to ensure desired flatness of the response within the passband. For a product which can also play music etc., the loudspeaker can have a wider frequency response; this should not degrade the performance of the voice pipeline.

The sensitivity should be sufficient for the application; it should be capable of producing 75 dB SPL at the user's ear location when a -18 dBFS signal is supplied. This can be considered the nominal sensitivity of the product. For a more general application, the maximum volume produced can be higher. However, much higher volumes will impact the ability to detect voice during playback.

The directivity of the loudspeaker should not affect the voice pipeline performance significantly. However, it may be possible to use a directional loudspeaker to achieve required levels at the user position while minimizing the feedback path to the microphones, and hence improving echo performance.

The most pressing consideration when incorporating loudspeakers into a design using the XVF3800 is the minimisation of non-linearities within the design. Whilst the XVF3800 features a linear echo canceller (the AEC), and whilst it can also suppress tail echo and non-linear echo, it is advisable to keep any non-linearities in the design to a minimum in order to guarantee optimal intelligibility and algorithmic performance.

The two main sources of non-linearity in a design arise from mechanical coupling between a loudspeaker and the microphones and from non-linearities present in the loudspeaker/amplifier stage itself. Efforts should be made to ensure that any loudspeakers are appropriately isolated from the microphones and placed physically as far away as feasible. Isolation may take the form of mechanical decoupling from the rest of the enclosure



---

and/or the use of soundproofing material between loudspeakers and the microphones. Additionally, product enclosures should be designed in such a manner as not to introduce non-linear effects; they should not rattle, click, vibrate, or otherwise introduce extraneous noise during normal operation.

Non-linearities present in the loudspeaker/amplifier stage are more difficult to provide generalised advice on.

Loudspeakers and amplifiers should be specified such that at nominal operating volume they are both operating within their linear region; this usually pushes design decisions towards larger or more powerful loudspeakers. As noted in the previous section, the loudspeakers at their maximum level should not be so loud that they push the microphones in the design to acoustic overload.

A THD of below 3 to 5%, measured over the full frequency range at the maximum level, is desirable. Designers should note that the THD for loudspeakers is typically only specified in datasheets at 1 kHz. THD can also be introduced by the amplifier used; it is important that amplifiers are chosen such that the overall THD of the loudspeaker system is minimised wherever possible.

Finally, it is important to consider the effect of loudspeaker placement on the far-field sensitivity of the device's microphones. In general for a given nominal level, the closer a microphone is placed to a loudspeaker the lower its gain must be in order to avoid clipping. This means that the closer a loudspeaker is located to a microphone, the lower the overall system gain will be, and therefore the lower the far-field sensitivity of the device.

## 6.3 Enclosure and mounting

The mechanical design of the product should account for the following:

The mounting of the loudspeaker and microphones should allow sound to propagate to and from the user without significant impediments, such that the performance of the transducers is not degraded.

The feedback path from the loudspeaker to the microphones should be minimized. The actual value of the attenuation required will vary depending on the application, but it generally should be as high as possible to reduce echo. Several possible paths are present and must be considered:

- The acoustic path outside of the enclosure can be minimized by increasing the distance between loudspeakers and microphones or by choosing a more highly directional loudspeaker,
- The acoustic path inside the enclosure can be minimized by sealing the rear chambers behind the loudspeakers and microphones, and
- The vibration path in the physical structure of the enclosure can be minimized by mechanical design of the housing structure, choice of materials, and mounting of the transducers. Whatever this path, this should also remain time-constant; transducers should be solidly mounted to the enclosure, or fully decoupled with foam.

Vibration of loose parts in the product can cause rattles and buzzes which creates non-linearity and will drastically reduce echo performance. Ensure all components, panels and connectors are fixed.

Microphones should be prevented from detecting any additional noise sources from the product, e.g., cooling fans.

The specifics of enclosure design, in particular relating to the acoustic performance of loudspeakers, is beyond the scope of this document. There is a wealth of literature covering this topic as well as consultancy services for design.

More detailed information on transducer mounting and handling can be found from the component manufacturers. They will also provide guidance on handling during manufacture and other important considerations.

Additionally, specification requirements for various product applications can be found in certification documents. These certifications will allow the product to bear a mark which demonstrates that the product is suitable for use with a particular service.

# 7 DFU operations

---

The Device Firmware Update (DFU) allows updating the firmware of the device from a host computer. The XVF3800 supports two different implementations of the DFU protocol: one over USB for the UA device and one over I<sup>2</sup>C for the INT device.

Only one upgrade image may be transferred to the flash of the XVF3800. The first upgrade image will be replaced by a subsequent upgrade process. The factory image cannot be overwritten and in case of DFU failure, the factory settings will be restored after rebooting the device.

---

**Note:** The DFU procedures of XVF3800 only support a transfer block size of 256 bytes over USB and 128 bytes over I<sup>2</sup>C.

---

## 7.1 Setting up the host computer (UA)

The UA build of the XVF3800 firmware is compliant with *dfu-util*. This is a host side implementation of the DFU 1.0 and DFU 1.1 specifications of the USB forum. The software is licensed under the GPL version 2. The instructions to download and install the application can be found in <https://dfu-util.sourceforge.net/>. The XVF3800 is compatible with the default release binaries from <https://dfu-util.sourceforge.net/releases/>. The host app is available for Linux, macOS, Raspberry Pi OS and Windows.

---

**Note:** In the rest of this document when using the *dfu-util* app in the code examples, the command is written as `(sudo) dfu-util(.exe)`. The `.exe` extension is only required on Windows. The `sudo` command is only required on Linux, macOS and Raspberry Pi OS if the user does not have the necessary permissions to access the device. On these platforms it may be necessary to use `./` before the command if the directory containing the *dfu-util* app is not in the `PATH`.

---

## 7.2 Setting up the host computer (INT)

The INT build of the XVF3800 firmware is able to perform DFU over an I<sup>2</sup>C interface, using a custom implementation closely following that set out by the USB Device Class Specification for DFU, Version 1.1. An example host application is included for the Raspberry Pi to showcase this implementation and to provide guidelines on how a custom compliant host application may be written. To use this application:

1. Set up the device as described in [Hardware Setup - I2S \(INT-Device\) Configuration](#).
2. Extract *xvf\_dfu*, *libdevice\_i2c.so*, *dfu\_cmds.yaml*, and *transport\_config.yaml* from the XVF3800 release package; these will be located in the `host_v<version>\rpi` directory.
3. The application may now be run from a terminal. Sudo privileges are required.

---

## 7.3 Generation of Binary Upgrade Image

The upgrade executable (.xe) needs to be converted into a binary format. Use *xflash* and the following command to convert the .xe application into a binary form:

```
xflash --noing --factory-version 15.2 --upgrade [UPGRADE_VERSION] [UPGRADE_EXECUTABLE] -o [OUTPUT_
↪BINARY]
```

Specify `--factory-version` value of 15.2 for all 15.3.x releases of the XTC tools. (The 15.2 value refers to boot loader API for the XTC tool chain).

---

**Note:** Should a different version of the XTC tools be used in a future firmware release, the tools version number should be noted such that an update image of compatible format can be created. The `--factory-version` must match the tools version used to build the factory image.

---

The `UPGRADE_VERSION` number is the 16-bit format `0xJJMP` of the executable firmware where:

- J is major
- M is minor
- P is patch

`UPGRADE_EXECUTABLE` is the path to the .xe application to convert. `OUTPUT_BINARY` is the path to the binary to generate.

The *dfu-util* application issues a warning if a suffix is not added to the upgrade binary. The suffix can be added using the *dfu-suffix* host application from <https://dfu-util.sourceforge.net/dfu-suffix.1.html>. The *xvf\_dfu* application issues no such warning.

---

## 7.4 Examples of DFU operations

Using either the `dfu-util` application or the `xvf_dfu` application the following operations can be performed.

---

**Note:** All the commands in this section that relate to the `dfu-util` application use the XMOS-supplied USB Vendor ID and USB Product ID for the XVF3800-UA device:

- Vendor ID 0x20b1, and either
- Product ID 0x4f00 for 48 kHz sample rate, or
- Product ID 0x4f01 for 16 kHz sample rate.

These values will change if the customer has used their own Vendor ID and Product ID.

---

The options used in the rest of the section are described in more detail in either the help menu of `dfu-util(.exe)`:

```
dfu-util(.exe) -h
```

or the help menu of `xvf_dfu`:

```
xvf_dfu -h
```

A more detailed description of the I<sup>2</sup>C implementation and its control process may be found in Section 2 of the Programming Guide.

### 7.4.1 Download an upgrade image to the device

The DFU download operation allows the user to upgrade the firmware of the XVF3800-UA. The command to do that is one of the following:

```
(sudo) dfu-util(.exe) -d 20b1:4f00 -a 1 -D [UPGRADE_BINARY] -R # 48 kHz sample rate
(sudo) dfu-util(.exe) -d 20b1:4f01 -a 1 -D [UPGRADE_BINARY] -R # 16 kHz sample rate
```

where `-a 1` is fixed and it indicates the altsetting for the upgrade image, and `UPGRADE_BINARY` is the path to the upgrade binary generated as described in [Generation of Binary Upgrade Image](#). The `-R` option will trigger a reboot of the device after the download is complete.

For the INT build of the device, the command sequence is the following:

```
sudo xvf_dfu -u i2c -d [UPGRADE_BINARY]
sudo xvf_dfu -u i2c -r
```

where `UPGRADE_BINARY` is the path to the upgrade binary generated as described in [Generation of Binary Upgrade Image](#), `-u i2c` selects I<sup>2</sup>C as the transport medium over which to send the device control commands (currently the only supported medium), and `-r` forces a reboot of the device. Should the download operation fail, both the `xvf_dfu` and `dfu-util` applications will exit with an error code. Another download operation may be reattempted; should this continue to fail, rebooting the device will reset the device into the factory image, as any pre-existing upgrade image has been corrupted by the failed DFU operation.

---

## 7.4.2 Revert the device to factory image

To restore the device to its factory configuration, effectively discarding any upgrades made, the same process as outlined above is followed but using a blank upgrade image. This is the only way a restore can be initiated, as the device does not have the ability to restore itself.

The blank file can be generated using `dd` on MAC and Linux, and `fsutil` on Windows. A blank image can be created with a file of zeroes the size of one flash sector. In the normal case of 4KB sectors on a UNIX-compatible platform, this can be created as follows:

```
dd bs=4096 count=1 < /dev/zero 2>/dev/null blank.bin
```

and for Windows systems:

```
fsutil file createNew blank.bin 4096
```

This process outlined in the [DFU download operation](#) section can now be followed using `blank.bin` file as `UPGRADE_BINARY`.

## 7.4.3 Reboot the device

The `dfu-util` application can be used to reboot the device via the USB interface. This can be done with one of the following commands:

```
(sudo) dfu-util(.exe) -d 20b1:4f00 -a 0 -e # 48 kHz sample rate
(sudo) dfu-util(.exe) -d 20b1:4f01 -a 0 -e # 16 kHz sample rate
```

In this command either `-a 0` and `-a 1` are valid.

Via the I<sup>2</sup>C interface, `xvf_dfu` may be used as:

```
sudo xvf_dfu -u i2c -r
```

## 7.4.4 Upload the images from the device

The DFU upload operation allows the user to read the factory and upgrade images of the XVF3800. This feature is useful for debugging purposes, for example to provide XMOS with the exact firmware used on a device. The command to do that in the UA build is one of the following:

```
(sudo) dfu-util(.exe) -d 20b1:4f00 -a [ALTSETTING] -U [IMAGE_BINARY] # 48 kHz sample rate
(sudo) dfu-util(.exe) -d 20b1:4f01 -a [ALTSETTING] -U [IMAGE_BINARY] # 16 kHz sample rate
```

where `ALTSETTING` is 0 for the factory image and 1 for the upgrade image, and `IMAGE_BINARY` is the path to the binary to store the image read from the device.

For the I<sup>2</sup>C implementation, `xvf_dfu` may be used as:

```
sudo xvf_dfu -u i2c -uf [IMAGE_BINARY]
```

to read the factory image to `IMAGE_BINARY`, or:

```
sudo xvf_dfu -u i2c -uu [IMAGE_BINARY]
```

to read the upgrade image to `IMAGE_BINARY`.

The uploaded upgrade image should match the same image created in [Generation of Binary Upgrade Image](#), but without any extra suffix.

The uploaded factory image contains the bootloader data and the image obtained using the command:

---

```
xflash [FACTORY_EXECUTABLE] -o [OUTPUT_BINARY]
```

where `FACTORY_EXECUTABLE` is the path to the `.xe` application flashed on the device and `OUTPUT_BINARY` is the path to the binary to generate.

---

**Note:** All the images uploaded from the device have some padding bytes, so that their size is a multiple of DFU transfer size. This value is set to 256 bytes by default in UA and 128 bytes in INT.

---

#### 7.4.4.1 Error handling

The XVF3800 device supports the following errors, and they are used only during the *download* operation:

- *errWRITE*: this error is returned if the host sends a download request for the wrong partition, for example the factory partition
- *errADDRESS*: this error is returned if the host sends a data block outside the address range of the memory partition, for example if the image is too large.

During the download operations, the device expects to receive the data blocks in the correct order, and it writes them to the flash as soon as they are received. The sequence number included in the download messages is not checked by the device.

If the following happens during a download or upload phase:

- the operations are interrupted by the host
- the device returns a DFU error

if the device is version 3.1.0 or higher, the user can restart the operation from the beginning of the image. For older versions, the device must be rebooted before resuming the DFU procedure. Resuming a download operation midway through an image is not supported in any version.

If the image downloaded to the device is not correct, for example if any data is corrupted or if the download is not completed, the upgrade image will be replaced, but after rebooting the bootloader will deem the upgrade image invalid, and the device will load the factory image.

## 8 Automatic speech recognition

---

The XVF3800 allows outputting audio enhanced for Automatic Speech Recognition (ASR). The ASR output provided by the XVF3800 is not optimized for voice communication, but it is meant to be used with wake word detection engines. The ASR audio is extracted after the beamformer, and it is not fed into the post processor. This means it has no noise suppression, which is desirable as ASR performance is usually degraded by non-linear processing. An optional fixed gain can be applied to match the requirements of different wake word engines.

The ASR output is not enabled by default. The XVF3800 can send the ASR audio to both the left and right channel. To use the right channel issue the commands:

```
(sudo) xvf_host(.exe) AUDIO_MGR_OP_R 7 3  
(sudo) xvf_host(.exe) AEC_ASROUTONOFF 1
```

The commands above map the output of autoselect beam in the right channel, see [Output Selection](#) for more details. The command `AEC_ASROUTONOFF` changes the output audio from the AEC residual of the fourth microphone to the output of autoselect beam. The left channel is used by default for the voice communication, but it can be configured as ASR output, by replacing the command `AUDIO_MGR_OP_R` above with `AUDIO_MGR_OP_L`.

The configurable fixed gain can be modified by using the command `AEC_ASROUTGAIN`. The desired output level will vary for each ASR engine. One recommendation is an output level of -52 dBov for a 61 dB SPL level at the device. Typically this will result in an `AEC_ASROUTGAIN` around 36 dB lower than `PP_AGCGAIN`, depending on the `PP_AGCDESIREDLEVEL`.

## 9 HID Interface

---

The UA variant of the device supports a HID interface. The HID interface adds support for USB standard input and output reports for a telephony device. The GPIO button and LEDs on the XK-VOICE-SQ66 development kit are mapped to buttons and LEDs in the HID input and output reports. The HID Interface design section of the Programming Guide describes the HID descriptors and the mapping between HID buttons/LEDs and the XK-VOICE-SQ66 development kit buttons/LEDs in more detail.



# 10 APPENDIX – Control Commands

There are a number of control commands available for use with the XVF3800. These are detailed using the `--list-commands` option of the Host Application, but may also be found below for reference. Note that all parameters in this appendix will be reset to their default values on a device reset.

## 10.1 AEC Tuning and Control Commands

These commands focus on tuning parameters for the AEC and postprocessing tasks.

Table 10.1: AEC control commands

Command name	Read / Write	Params	Param format	Description
SHF_BYPASS	READ / WRITE	1	uint8	AEC bypass
AEC_NUM_MICS	READ ONLY	1	int32	Number of microphone inputs into the AEC
AEC_NUM_FARENDS	READ ONLY	1	int32	Number of farend inputs into the AEC
AEC_MIC_ARRAY_TYPE	READ ONLY	1	int32	Microphone array type (1 - linear, 2 - squarecircular)
AEC_MIC_ARRAY_GEO	READ ONLY	12	float	Microphone array geometry. Each microphone is represented by 3 XYZ coordinates in m.
AEC_AZIMUTH_VALUES	READ ONLY	4	radians	Azimuth values in radians - beam 1, beam 2, free-running beam, 3 - auto-select beam
AEC_CURRENT_IDLE_TIME	READ ONLY	1	uint32	AEC processing current idle time in 10ns ticks
AEC_MIN_IDLE_TIME	READ ONLY	1	uint32	AEC processing minimum idle time in 10ns ticks
AEC_RESET_MIN_IDLE_TIME	WRITE ONLY	1	uint32	Reset the AEC minimum idle time. The value of the argument passed is ignored.
AEC_SPENERGY_VALUES	READ ONLY	4	float	Speech energy level values for each beam. Any value above 0 indicates speech. Higher values indicates louder or closer speech, however noise, echo and reverb can cause the energy level to decrease. 0 - beam 1, 1 - beam 2, 2 - free-running beam, 3 - auto-select beam
AEC_FIXEDBEAMSAZIMUTH_VALUES	READ / WRITE	2	radians	Azimuth values in radians for beams in fixed mode - fixed beam 1, fixed beam 2. Default value(s): (0,0)
AEC_FIXEDBEAMSELEVATION_VALUES	READ / WRITE	2	radians	Elevation angles in radians for the beams in fixed mode. 0 - fixed beam 1, 1 - fixed beam 2. Default value(s): (0,0)
AEC_FIXEDBEAMSGATING	READ / WRITE	1	uint8	Enables/disables gating for beams in fixed mode. When enabled, speech energy is used to determine which beam should be active; inactive beams are silenced. Default value(s): 0

continues on next page



Table 10.1 – continued from previous page

Command name	Read / Write	Params	Param format	Description
AEC_FILTER_CMD_ABORT	WRITE ONLY	1	int32	Reset the special command state machine. Used for safely exiting from an AEC filter read/write command sequence that has gone wrong.
AEC_AECPATHCHANGE	READ ONLY	1	int32	AEC Path Change Detection. Valid range: 0,1 (false,true)
AEC_HPFONOFF	READ / WRITE	1	int32	High-pass Filter on microphone signals. Valid range: 0,1,2,3,4 (0:Off, 1:on70, 2:on125, 3:on150, 4:on180). Default value(s): on125
AEC_AECSILENCELEVEL	READ / WRITE	2	float	Power threshold for signal detection in adaptive filter.(set,cur), Valid range (set): [0.0 .. 1.0] Valid range (cur): 0.05*set, 1e-6f or set.. Default value(s): 1e-9f
AEC_AECCONVERGED	READ ONLY	1	int32	Flag indicating whether AEC is converged. Valid range: 0,1 (false,true). Default value(s): False
AEC_AECEMPHASISONOFF	READ / WRITE	1	int32	Pre-emphasis and de-emphasis filtering for AEC. Valid range: 0,1,2 (off,on,on_eq)on: Emphasis filter for speech signals without modification of far-end ref. on_eq: Emphasis filter for far-end reference signals where the low frequencies are boosted by e.g. an equalizer.. Default value(s): 1
AEC_FAR_EXTGAIN	READ / WRITE	1	float	External gain in dB applied to the far-end reference signals. Valid range: [-inf .. inf]. Default value(s): 0.0dB
AEC_PCD_COUPLINGI	READ / WRITE	1	float	Sensitivity parameter for PCD. Valid range: [0.0 .. 1.0]PCD can be disabled by setting a value outside the range. Default value(s): disabled
AEC_PCD_MINTHR	READ / WRITE	1	float	Minimum threshold value used in PCD. Valid range: [0.0 .. 0.02]. Default value(s): 0.005
AEC_PCD_MAXTHR	READ / WRITE	1	float	Maximum threshold value used in PCD. Valid range: [0.025 .. 0.2]. Default value(s): 0.1
AEC_RT60	READ ONLY	1	float	Current RT60 estimate. Valid range: [0.250 .. 0.900] (seconds) A negative value indicates that the RT60 estimation is invalid.
AEC_ASROUTONOFF	READ / WRITE	1	int32	Enables the automatic speech recognition (ASR) output: if set to 0, the AEC residuals are output, one channel per microphone, if set to 1, the ASR processed output is used, where each channel is associated with a beam from the beamformer. Valid range: 0,1 (off, on). Default value(s): 0
AEC_ASROUTGAIN	READ / WRITE	1	float	Fixed gain applied to qsr output, i.e., only applied if ASROUTONOFF==1.. Valid range: [0.0 .. 1000.0] (linear gain factor). Default value(s): 1.0

continues on next page

Table 10.1 – continued from previous page

Command name	Read / Write	Params	Param format	Description
AEC_FIXEDBEAMSONOFF	READ / WRITE	1	int32	Enables or disables fixed focused beam mode. Valid range: 0,1 (off, on). Default value(s): False
AEC_FIXEDBEAMNOISETHR	READ / WRITE	2	float	Threshold value for updating the noise canceller when fixed beam mode is enabled. A higher value indicates that the noise canceller may update when the free running beam is close to the fixed beam. A lower value indicates that the noise canceller may update when the free running beam is further away from the focused beam.[BECLEAR_NUMBER_OF_BEAMS], Valid range: [0.0 .. 1.0]. Default value(s): (0.4,0.4)

Table 10.2: PP control commands

Command name	Read / Write	Params	Param format	Description
PP_CURRENT_IDLE_TIME	READ ONLY	1	uint32	PP processing current idle time in 10ns ticks
PP_MIN_IDLE_TIME	READ ONLY	1	uint32	PP processing minimum idle time in 10ns ticks
PP_RESET_MIN_IDLE_TIME	WRITE ONLY	1	uint32	Reset the PP minimum idle time. The value of the argument passed is ignored.
PP_NL_MODEL_CMD_ABORT	WRITE ONLY	1	int32	Reset the special command state machine. Used for safely exiting from a NL model read/write sequence that has gone wrong.
PP_EQUALIZATION_CMD_ABORT	WRITE ONLY	1	int32	Reset the special command state machine. Used for safely exiting from an equalization read/write sequence that has gone wrong.
PP_AGCONOFF	READ / WRITE	1	int32	Automatic Gain Control. Valid range: 0,1 (off,on). Default value(s): True
PP_AGCMAXGAIN	READ / WRITE	1	float	Maximum AGC gain factor. Valid range: [1.0 .. 1000.0] (linear gain factor). Default value(s): 125.0
PP_AGCDESIREDLEVEL	READ / WRITE	1	float	Target power level of the output signal. Valid range: [1e-8 .. 1.0] (power level). Default value(s): 0.0045
PP_AGCGAIN	READ / WRITE	1	float	Current AGC gain factor. Valid range: [1.0 .. 1000.0] (linear gain factor). Default value(s): 32.0
PP_AGCTIME	READ / WRITE	1	float	Ramp-up/down time-constant. Valid range: [0.5 .. 4.0] (seconds). Default value(s): 0.9
PP_AGCFASTTIME	READ / WRITE	1	float	Ramp down time-constant in case of peaks. Valid range: [0.05 .. 4.0] (seconds). Default value(s): 0.1f

continues on next page

Table 10.2 – continued from previous page

Command name	Read / Write	Params	Param format	Description
PP_AGCALPHAFASTGAIN	READ / WRITE	1	float	Gain threshold enabling fast alpha mode. Valid range: [0.0 .. 1000.0] (linear gain factor). Default value(s): 0.0
PP_AGCALPHASLOW	READ / WRITE	1	float	Slow memory parameter for speech power. Valid range [0.0 .. 1.0]. Default value(s): 0.984
PP_AGCALPHAFAST	READ / WRITE	1	float	Fast memory parameter for speech power. Valid range [0.0 .. 1.0]. Default value(s): 0.36
PP_LIMITONOFF	READ / WRITE	1	int32	Limiter on communication output. Valid range: 0,1 (off,on). Default value(s): True
PP_LIMITPLIMIT	READ / WRITE	1	float	Maximum limiter power. Valid range: [1e-8 .. 1.0] (power level). Default value(s): 0.47
PP_MIN_NS	READ / WRITE	1	float	Gain-floor for stationary noise suppression. Valid range: [0.0 .. 1.0]. Default value(s): 0.15
PP_MIN_NN	READ / WRITE	1	float	Gain-floor for non-stationary noise suppression. Valid range: [0.0 .. 1.0]. Default value(s): 0.51
PP_ECHOONOFF	READ / WRITE	1	int32	Echo suppression. Valid range: 0,1 (off,on). Default value(s): True
PP_GAMMA_E	READ / WRITE	1	float	Over-subtraction factor of echo (direct and early components). Valid range: [0.0 .. 2.0]. Default value(s): 1.0
PP_GAMMA_ETAIL	READ / WRITE	1	float	Over-subtraction factor of echo (tail components). Valid range: [0.0 .. 2.0]. Default value(s): 1.0
PP_GAMMA_ENL	READ / WRITE	1	float	Over-subtraction factor of non-linear echo. Valid range: [0.0 .. 5.0]. Default value(s): 1.1
PP_NLATTENONOFF	READ / WRITE	1	int32	Non-Linear echo attenuation. Valid range: 0,1 (off,on). Default value(s): 1
PP_NLAEC_MODE	READ / WRITE	1	int32	Non-Linear AEC training mode. Valid range: 0,1,2 (normal,train,train2). Default value(s): 0
PP_MGSCALE	READ / WRITE	3	float	Minimum gain scale for acoustic echo suppression.(max,min,cur), Valid range (max,min): [(1.0,0.0) .. (1e5,max)] Valid range (cur): min or max.. Default value(s): (1000.0,1.0)
PP_FMIN_SPEINDEX	READ / WRITE	1	float	In case of double talk, frequencies below SPEINDEX are more suppressed than frequencies above SPEINDEX. The actual suppression is depending on the setting of DT-SENSITIVE. The parameter is not a taste parameter but needs to be tuned for a specific device. Valid range: [0.0 .. 7999.0]. Default value(s): 593.75

continues on next page

Table 10.2 – continued from previous page

Command name	Read / Write	Params	Param format	Description
PP_DTSENSITIVE	READ / WRITE	1	int32	Tradeoff between echo suppression and doubletalk performance. A lower value prefers high echo suppression (possibly at the cost of less doubletalk performance), a higher value prefers better doubletalk performance (possibly at the cost of good echo suppression). Good doubletalk performance is only possible for hardware without much non-linearities. When the value has 2 digits, for robustness an extra near-end speech detector is used. Valid range: [0 .. 5, 10 .. 15]. Default value(s): 0
PP_ATTNS_MODE	READ / WRITE	1	int32	Additional reduction of AGC gain during non-speech. Valid range: 0,1 (off, on). Default value(s): 0
PP_ATTNS_NOMINAL	READ / WRITE	1	float	Amount of additional reduction during non-speech at nominal speech level. Valid range: [0.0 .. 1.0]. Default value(s): 1.0
PP_ATTNS_SLOPE	READ / WRITE	1	float	Determines the extra amount of suppression during non-speech when the AGC level increases at lower speech level. The extra attenuation is given by $(agc\_gain\_nominal/agc\_gain\_current)^{attns\_slope}$ . With a value of 1.0 the amount of noise in the output remains approximately the same, independent of the agc gain. Valid range: [0.0 .. 5.0]. Default value(s): 1.0

## 10.2 Device Metadata Commands

These commands focus on querying the device's metadata, e.g. software version, boot status, and build information.

Table 10.3: Metadata control commands

Command name	Read / Write	Params	Param format	Description
VERSION	READ ONLY	3	uint8	The version number of the firmware. The format is VERSION_MAJOR VERSION_MINOR VERSION_PATCH
BLD_MSG	READ ONLY	50	char	Retrieve the build message built in to the firmware, normally the build configuration name
BLD_HOST	READ ONLY	30	char	Retrieve details of the CI build host used to build the firmware
BLD_REPO_HASH	READ ONLY	40	char	Retrieve the GIT hash of the sw_xvf3800 repo used to build the firmware
BLD_MODIFIED	READ ONLY	6	char	Show whether or not the current firmware repo has been modified from the official release. Requires use of a GIT repo
BOOT_STATUS	READ ONLY	3	char	Shows whether or not the firmware has been booted via SPI or JTAG/FLASH
REBOOT	WRITE ONLY	1	uint8	Set to any value to reboot the chip and reset all parameters to default.
USB_BIT_DEPTH	READ / WRITE	2	uint8	Only relevant for the UA device variant. For the UA device, set or get the USB bit depth IN, OUT to either 16, 24 or 32. Setting will reboot the chip, resetting all other parameters to default. If issued to the INT device, a set is ignored and the device is not rebooted while a get always returns 0 as both IN and OUT bit depths.. Valid range: val0: [16 .. 16] val0: [24 .. 24] val0: [32 .. 32] val1: [16 .. 16] val1: [24 .. 24] val1: [32 .. 32]

## 10.3 Audio Manager Commands

These commands are targeted toward setting and retrieving various options around the audio path into and out of the device, including setting I<sup>2</sup>S loopback modes and debug “packed” IO modes. Includes diagnostic data on idle times for both the audio manager core and the I<sup>2</sup>S core.

**Note:** For an example on the use of “packed” IO, see the *Signal Capture* section of the *Programming Guide*<Signal\_Capture>. For more information on options for setting AUDIO\_MGR\_OP\_\*, see the *Output Selection* section of the *User Guide*.

Table 10.4: Audio Manager control commands

Command name	Read / Write	Params	Param format	Description
AUDIO_MGR_MIC_GAIN	READ / WRITE	1	float	Audio Mgr pre SHF microphone gain. Default value(s): 10
AUDIO_MGR_REF_GAIN	READ / WRITE	1	float	Audio Mgr pre SHF reference gain. Default value(s): 1.5
AUDIO_MGR_CURRENT_IDLE_TIME	READ ONLY	1	int32	Get audio manager current idle time in 10ns ticks
AUDIO_MGR_MIN_IDLE_TIME	READ ONLY	1	int32	Get audio manager min idle time in 10ns ticks
AUDIO_MGR_RESET_MIN_IDLE_TIME	WRITE ONLY	1	int32	Reset audio manager min idle time. The value of the argument passed is ignored.
AUDIO_MGR_MAX_CONTROL_TIME	READ ONLY	1	int32	Get audio manager max control time
RESET_MAX_CONTROL_TIME	WRITE ONLY	1	int32	Reset audio manager max control time. The value of the argument passed is ignored.
I2S_CURRENT_IDLE_TIME	READ ONLY	1	int32	Get I2S current idle time in 10ns ticks
I2S_MIN_IDLE_TIME	READ ONLY	1	int32	Get I2S min idle time in 10ns ticks
I2S_RESET_MIN_IDLE_TIME	WRITE ONLY	1	int32	I2S reset idle time. The value of the argument passed is ignored.
I2S_INPUT_PACKED	READ / WRITE	1	uint8	Will expect packed input on both I2S or USB channels if this is not 0. Note, could take up to 3 samples to take effect.. Valid range: val0: [0 .. 1]. Default value(s): 0
AUDIO_MGR_SELECTED_AZIMUTHS	READ ONLY	2	radians	This returns the azimuths determined by the beam_selection function in post_shf_dsp.c. The default implementation will provide a processed DoA at index 0 and the DoA of the auto select beam at index 1. The processed DoA uses speech energy to select from the DoA on each fixed beam to provide the direction of a speaker. NAN will be returned if neither of the fixed beams contain speech. Versions 2.0.0 and earlier of XVF3800 had a different default implementation of beam_selection which returned the DoA associated with the AUDIO_MGR_SELECTED_CHANNELS

continues on next page



Table 10.4 – continued from previous page

Command name	Read / Write	Params	Param format	Description
AU-DIO_MGR_SELECTED_CH ANNELS	READ / WRITE	2	uint8	Default implementation of post processing will use this to select which channels should be output to MUX_USER_CHOSEN_CHANNELS. Note that a customer implementation of the beam selection stage could override this command. How this channel selection aligns with actual output depends on the mux configuration. Valid range: val0: [0 .. 3] val1: [0 .. 3]. Default value(s): (3, 3)
AUDIO_MGR_OP_PACKED	READ / WRITE	2	uint8	<L>, <R>; Sets/gets packing status for L and R output channels. Valid range: val0: [0 .. 1] val1: [0 .. 1]. Default value(s): (0, 0)
AU-DIO_MGR_OP_UPSAMPLE	READ / WRITE	2	uint8	<L>, <R>; Sets/gets upsample status for L and R output channels, where appropriate. Valid range: val0: [0 .. 1] val1: [0 .. 1]
AUDIO_MGR_OP_L	READ / WRITE	2	uint8	<category>, <source>; Sets category and source for L output channel. Equivalent to AUDIO_MGR_OP_L_PK0. Valid range: val0: [0 .. 12] val1: [0 .. 5]. Default value(s): (8, 0)
AUDIO_MGR_OP_L_PK0	READ / WRITE	2	uint8	<category>, <source>; Sets category and source for first (of three) sources on the L channel in packed mode. Equivalent to AUDIO_MGR_OP_L. Valid range: val0: [0 .. 12] val1: [0 .. 5]
AUDIO_MGR_OP_L_PK1	READ / WRITE	2	uint8	Sets category and source for second (of three) sources on the L channel in packed mode. Valid range: val0: [0 .. 12] val1: [0 .. 5]. Default value(s): (1, 0)
AUDIO_MGR_OP_L_PK2	READ / WRITE	2	uint8	Sets category and source for third (of three) sources on the L channel in packed mode. Valid range: val0: [0 .. 12] val1: [0 .. 5]. Default value(s): (1, 2)
AUDIO_MGR_OP_R	READ / WRITE	2	uint8	<category>, <source>; Sets category and source for R output channel. Equivalent to AUDIO_MGR_OP_R_PK0. Valid range: val0: [0 .. 12] val1: [0 .. 5]. Default value(s): (0, 0)
AUDIO_MGR_OP_R_PK0	READ / WRITE	2	uint8	<category>, <source>; Sets category and source for first (of three) sources on the R channel in packed mode. Equivalent to AUDIO_MGR_OP_R. Valid range: val0: [0 .. 12] val1: [0 .. 5]
AUDIO_MGR_OP_R_PK1	READ / WRITE	2	uint8	Sets category and source for second (of three) sources on the R channel in packed mode. Valid range: val0: [0 .. 12] val1: [0 .. 5]. Default value(s): (1, 1)
AUDIO_MGR_OP_R_PK2	READ / WRITE	2	uint8	Sets category and source for third (of three) sources on the R channel in packed mode. Valid range: val0: [0 .. 12] val1: [0 .. 5]. Default value(s): (1, 3)

continues on next page



Table 10.4 – continued from previous page

Command name	Read / Write	Params	Param format	Description
AUDIO_MGR_OP_ALL	READ / WRITE	12	uint8	Sets category and source for all 3 sources on L channel and all 3 sources for R channel. Equivalent to AUDIO_MGR_OP_[L,R]_PK[0,1,2] with successive pairs of arguments. Valid range: val0: [0 .. 12] val1: [0 .. 5] val2: [0 .. 12] val3: [0 .. 5] val4: [0 .. 12] val5: [0 .. 5] val6: [0 .. 12] val7: [0 .. 5] val8: [0 .. 12] val9: [0 .. 5] val10: [0 .. 12] val11: [0 .. 5]
I2S_INACTIVE	READ ONLY	1	uint8	Returns whether the main audio loop is exchanging samples with I2S (0). If not (1), I2S is inactive
AUDIO_MGR_FAR_END_DSP_ENABLE	READ / WRITE	1	uint8	Enables/disables XVF3800 far-end DSP (if implemented). Write a 1 to enable, 0 to disable. Valid range: val0: [0 .. 1]. Default value(s): 0
AUDIO_MGR_SYS_DELAY	READ / WRITE	1	int32	Delay, measured in samples, that is applied to the reference signal before passing to SHF algorithm. Valid range: val0: [-64 .. 256]. Default value(s): -32
I2S_DAC_DSP_ENABLE	READ / WRITE	1	uint8	Indicates if the DAC performs DSP on the far-end reference signal. If enabled (1), use the I2S signal as input to the audio pipeline, even in the UA configuration. Valid range: val0: [0 .. 1]. Default value(s): 0

## 10.4 GPIO Commands

These commands set up and manipulate various functions of the device's GPO and GPI services.

Table 10.5: GPIO control commands

Command name	Read / Write	Params	Param format	Description
GPI_INDEX	READ / WRITE	1	uint8	Set/get pin index for next and subsequent GPI reads. Maximum value should be equal to GPIO_NUM_INPUT_PINS. Valid range: val0: [0 .. 1]
GPI_EVENT_CONFIG	READ / WRITE	1	uint8	Set/get event config for selected pin. Valid range: val0: [0 .. 3]
GPI_ACTIVE_LEVEL	READ / WRITE	1	uint8	Set/get active level for selected pin
GPI_VALUE	READ ONLY	1	uint8	Get current logic level of selected GPI pin.
GPI_EVENT_PENDING	READ ONLY	1	uint8	Get whether event was triggered for selected GPI pin. Event flag is cleared for the pin. Interrupt pin is set when all event flags are cleared
GPI_VALUE_ALL	READ ONLY	1	uint32	Get current logic level of all GPI pins as a bitmap, where GPI index n -> bit n of returned value.
GPI_EVENT_PENDING_ALL	READ ONLY	1	uint32	Get whether event was triggered for all GPI pins as a bitmap, where GPI index n -> bit n of returned value. Event flag is cleared for all GPI pins. Interrupt pin is set.
GPO_PORT_PIN_INDEX	READ / WRITE	2	uint32	GPO port index and pin index that the following commands would be directed to. Valid range: val0: [0 .. 0] val1: [3 .. 7]
GPO_PIN_VAL	WRITE ONLY	3	uint8	value to write to one pin of a GPO port. Payload specifies port_index, pin_index and value to write to the pin. Valid range: val0: [0 .. 0] val1: [3 .. 7] val2: [0 .. 1]
GPO_PIN_ACTIVE_LEVEL	READ / WRITE	1	uint32	Active level of the port/pin specified by the GPO_PORT_PIN_INDEX command. 1 = ACTIVE_HIGH, 0 = ACTIVE_LOW. Valid range: val0: [0 .. 1]
GPO_PIN_PWM_DUTY	READ / WRITE	1	uint8	PWM duty cycle of the pin specified by the GPO_PORT_PIN_INDEX command. Specified as an integer percentage between 0 and 100. Valid range: val0: [0 .. 100]
GPO_PIN_FLASH_MASK	READ / WRITE	1	uint32	Serial flash mask for the pin specified by the GPO_PORT_PIN_INDEX command. Each bit in the mask specifies the GPO pin state for a 100 ms time period interval

# 11 APPENDIX – Tuning the Loudspeaker

Tuning the XVF3800 to optimise loudspeaker performance with the XK-VOICE-SQ66 development kit involves four steps:

1. Optionally adding EQ to the loudspeaker frequency response,
2. Setting the maximum loudspeaker volume,
3. Retraining the non-linear matrix in the XVF3800 audio pipeline,
4. Rebuilding the XVF3800 executable image.

## 11.1 Adding EQ to the Loudspeaker Frequency Response

Many communication specifications expect roll-off at low frequencies, e.g., as shown in [Fig. 11.1](#).

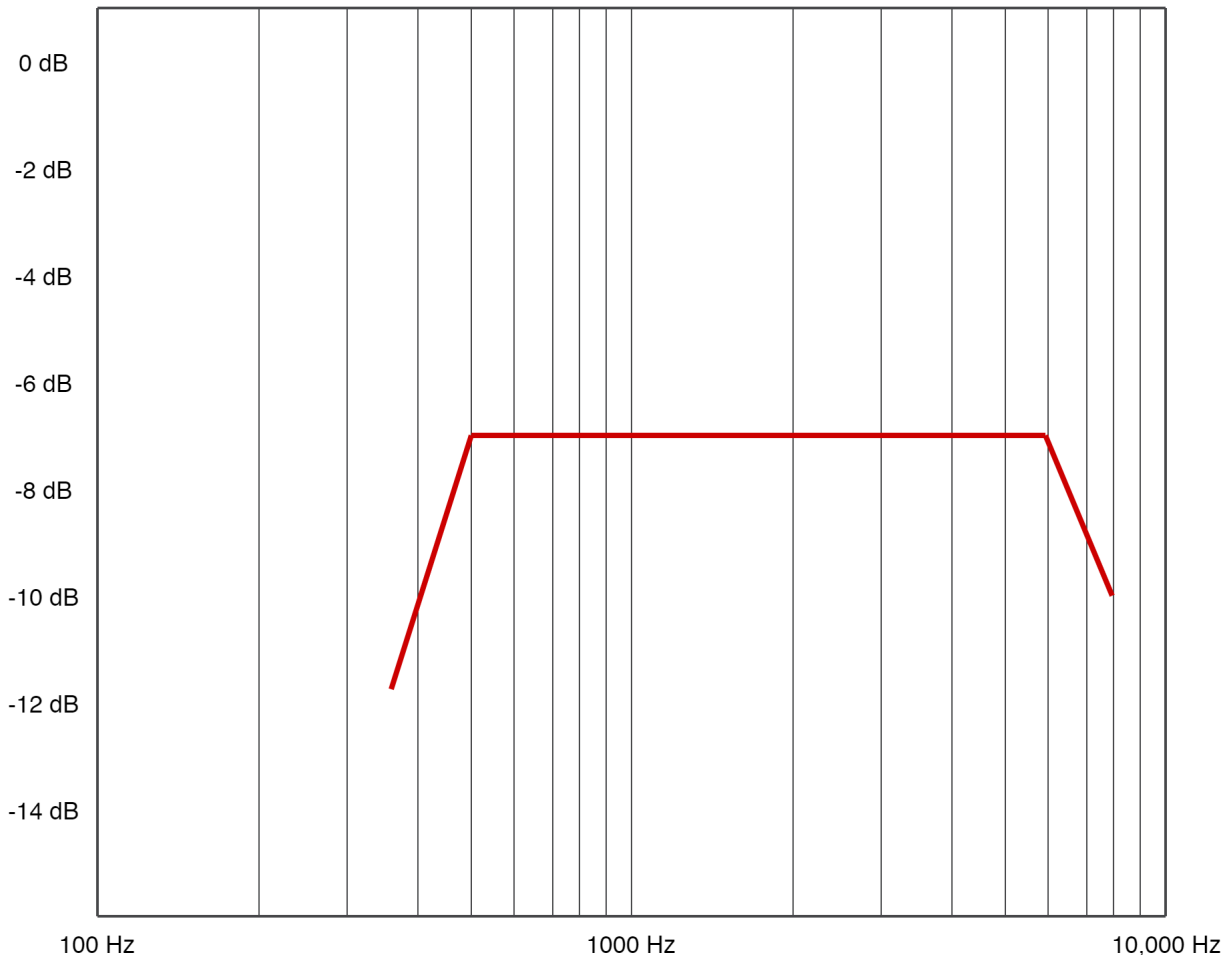

Fig. 11.1: Frequency response mask for a typical communication specification

Small loudspeakers often have a boost at 100-200 Hz to add more bass to the sound. This may need to be removed to meet the specification, e.g., by adding a low shelf to reduce the response by 6 to 10 dB. The steps below describe the process:

- 
1. Use the [Room EQ Wizard \(REW\)](#) to determine the filtering to add. Start by measuring the loudspeaker response at a close distance, then add EQ filters to shape the response as required.
  2. Use the [Audio EQ Cookbook equations](#) to generate biquad coefficients.
  3. Convert these coefficients into [the format used with the Texas Instruments TLV320DAC3101 Digital to Analogue Converter](#).
  4. Set the biquad in the [TLV320DAC3101](#) DAC on the XK-VOICE-SQ66 development kit using its page 8 registers. Table 6-14 of the TLV320DAC3101 datasheet provides some useful details.

---

**Note:** The Python script `sources/modules/bsp/dac/dac3101/dac3101_biquad_converter.py` provides support for generating the biquad coefficients and converting them into the form required by the TLV320DAC3101 Digital to Analogue Converter.

---

## 11.2 Setting the Maximum Loudspeaker Volume

See [Speaker Operation](#) for information on setting the loudspeaker volume. When using the [TLV320DAC3101](#), registers 36 (0x24) and 37 (0x25) in page 1 may require new values. Tables 6-24, 6-103, and 6-104 of the TLV320DAC3101 datasheet provide useful details.

## 11.3 Remaining Steps

Check the mic level with the new loudspeaker, see [Microphone Gain](#). To retrain the non-linear matrix in the XVF3800 audio pipeline, see [Tuning the Non-Linear Model](#). To rebuild the XVF3800 executable image, see [Building the Application Firmware](#).

## 12 APPENDIX – Alternative Tuning Parameters

---

The default tuning parameters have been selected such the XK-VOICE-SQ66 development kit will perform well against the Microsoft Teams V5 “Personal Space Speakerphone” specification. Parameters related to the loudspeaker, such as EQ and the non-linear model, are unique to specific loudspeakers. Different gain and AGC settings may also be needed, depending on the requirements of the specification.

In this appendix, alternative tuning parameters for specific loudspeakers and specifications are provided:

- MS Teams V5 Personal Space Speakerphone using a Logitech Z50 loudspeaker
- MS Teams V5 Shared Space Speakerphone at 4.5 m using a Genelec 8020 loudspeaker

### 12.1 Personal Space Speakerphone using a Logitech Z50 loudspeaker

For meeting the Teams Personal Space Speakerphone specification using a Logitech Z50 loudspeaker, the following changes are required:

- DAC output needs an attenuation of low frequencies using a low shelf filter (280 Hz, -6 dB gain, Q=1.3) to remove the low frequency boost caused by the table under the loudspeaker.
- Microphone gain can be increased, the Logitech Z50 has a low maximum SPL so this can occur without the risk of clipping the microphone signal.
- Non-linear model must be trained to match the non-linearities of the Logitech Z50 with this DAC EQ and microphone gain.
- AGC gain and maximum gain must be adjusted for microphone gain for a speech level of 89 dB SPL at the mouth reference point.

This requires changes to the following files:

- `sources/app_xvf3800/autogeneration/yaml_files/settings_and_defaults/control_param_values.yaml`
- `sources/app_xvf3800/nl_model_gen/nlmodel_bin/nlmodel_buffer_override.bin.r16.c40`
- `sources/modules/fw_k_xvf/modules/bsp/dac/dac3101.c`

Copies of these files configured for the Logitech Z50 are included in the folder `sources/app_xvf3800/configurations/logitech_z50`. Copy each file from the folder to their respective locations listed above. The firmware can then be built using the instructions in [Build Process](#), and flashed to the device.

The Logitech Z50 has no controls, so requires no additional configuration. Simply connect its 3.5 mm input cable to the line out on the XK-VOICE-SQ66 development kit.

---

## 12.2 Shared Space Speakerphone at 4.5 m using a Genelec 8020 loudspeaker

For meeting the Teams Shared Space Speakerphone at 4.5 m specification using a Genelec 8020 loudspeaker, the following changes are required:

- XK-VOICE-SQ66 development kit line output must be configured to balanced to match the Genelec 8020 input. This involves setting the DAC registers for differential output mode, see the [TLV320DAC3101](#) datasheet for more details. Note that connecting a balanced output to a stereo input will result in a very small signal level if the channels are summed.
- Line out volume must be reduced by 1.5 dB to set maximum loudspeaker SPL within limits.
- DAC output needs an attenuation of low frequencies using a low shelf filter (328 Hz, -10 dB, Q=1.1) to remove the low frequency boost caused by the table under the loudspeaker.
- DAC output also needs a 150 Hz high pass filter (Q=0.707) applied to reduce loudspeaker bass level. This filter is applied twice.
- Non-linear model must be trained to match the non-linearities of the Genelec 8020 with this DAC EQ and microphone gain.
- Slower AGC parameters are needed. This is to avoid collisions with the Teams Client AGC, which is also included in the signal path for the specification. This improves the MOS (Mean Opinion Score) in echo tests with the Teams client.
- Equalization filter must be applied to the processed output to fit within the send frequency response limits in the specification.
- A small increase in noise suppression is required to meet test specification.

This requires changes to the following files:

- `sources/app_xvf3800/autogeneration/yaml_files/settings_and_defaults/control_param_values.yaml`
- `sources/app_xvf3800/nl_model_gen/nlmodel_bin/nlmodel_buffer_override.bin.r16.c40`
- `sources/app_xvf3800/eq_filter_gen/eq_filter_bin/eq_filter_override.bin`
- `sources/modules/fwkw_xvf/modules/bsp/dac/dac3101.c`

Copies of these files configured for the Genelec 8020 are included in the folder `sources/app_xvf3800/configurations/genelec_8020`. Copy each file from the folder to their respective locations listed above. The firmware can then be built using the instructions in [Build Process](#), and flashed to the device.

To configure the Genelec 8020 loudspeaker, set all the switches on the rear down. The sensitivity control should be set to +6 dB (fully anti-clockwise), which is the quietest setting. An XLR-to-TRS jack cable, with a 6.35 mm to 3.5 mm jack adapter, is required to connect to the line out on the XK-VOICE-SQ66 development kit.

# 13 APPENDIX – List of applications

---

The application file names are described here.

More information about the applications below can be found in the User Guide.

All paths are relative to the /binaries/ directory in the release package.

## 13.1 UA device applications

---

### Build with USB audio at 16 kHz

---

/usb/16kHz/application_xvf3800_ua-io16-lin.xe	linear microphone array, control over USB
/usb/16kHz/application_xvf3800_ua-io16-sqr.xe	square/rectangular microphone array, control over USB

---

### Build with USB audio at 48 kHz

---

/usb/48kHz/application_xvf3800_ua-io48-lin.xe	linear microphone array, control over USB
/usb/48kHz/application_xvf3800_ua-io48-sqr.xe	square/rectangular microphone array, control over USB
/additional/application_xvf3800_ua-io48-lin-io-exp.xe	linear microphone array, control over USB, and I2C-to-IO expander to control buttons and LEDs
/additional/application_xvf3800_ua-io48-lin-spatial.xe	linear microphone array, control over USB, and mapping of focused beams to stereo output

---

## 13.2 INT device applications

---

### Build with I2S audio at 16 kHz

---

/i2s/16kHz/i2c/application_xvf3800_intdev-lr16-lin-i2c.xe	linear microphone array, control over I2C slave
/i2s/16kHz/i2c/application_xvf3800_intdev-lr16-sqr-i2c.xe	square/rectangular microphone array, control over I2C slave
/i2s/16kHz/spi/application_xvf3800_intdev-lr16-lin-spi.xe	linear microphone array, control over SPI slave
/i2s/16kHz/spi/application_xvf3800_intdev-lr16-sqr-spi.xe	square/rectangular microphone array, control over SPI slave
/additional/external_master_clock/application_xvf3800_intdev-lr16-lin-i2c-extmclk.xe	linear microphone array, control over I2C slave, and external Master clock
/additional/external_master_clock/application_xvf3800_intdev-lr16-sqr-i2c-extmclk.xe	square/rectangular microphone array, control over I2C slave, and external Master clock
/additional/external_master_clock/application_xvf3800_intdev-lr16-lin-spi-extmclk.xe	linear microphone array, control over SPI slave, and external Master clock
/additional/external_master_clock/application_xvf3800_intdev-lr16-sqr-spi-extmclk.xe	square/rectangular microphone array, control over SPI slave, and external Master clock

---



---

## Build with I2S audio at 48 kHz

---

/additional/application_xvf3800_intdev-lr48-lin-i2c-spatial.xe	linear microphone array, control over I2C slave, and mapping of focused beams to stereo output
/i2s/48kHz/i2c/application_xvf3800_intdev-lr48-lin-i2c.xe	linear microphone array, control over I2C slave
/i2s/48kHz/i2c/application_xvf3800_intdev-lr48-sqr-i2c.xe	square/rectangular microphone array, control over I2C slave
/i2s/48kHz/spi/application_xvf3800_intdev-lr48-lin-spi.xe	linear microphone array, control over SPI slave
/i2s/48kHz/spi/application_xvf3800_intdev-lr48-sqr-spi.xe	square/rectangular microphone array, control over SPI slave
/additional/external_master_clock/application_xvf3800_intdev-lr48-lin-i2c-extmclk.xe	linear microphone array, control over I2C slave, and external Master CLK
/additional/external_master_clock/application_xvf3800_intdev-lr48-sqr-i2c-extmclk.xe	square/rectangular microphone array, control over I2C slave, and external Master CLK
/additional/external_master_clock/application_xvf3800_intdev-lr48-lin-spi-extmclk.xe	linear microphone array, control over SPI slave, and external Master CLK
/additional/external_master_clock/application_xvf3800_intdev-lr48-sqr-spi-extmclk.xe	square/rectangular microphone array, control over SPI slave, and external Master CLK

---





Copyright © 2024, XMOS Ltd

---

XMOS Ltd. is the owner or licensee of this design, code, or Information (collectively, the "Information") and is providing it to you "AS IS" with no warranty of any kind, express or implied and shall have no liability in relation to its use. XMOS Ltd makes no representation that the Information, or any particular implementation thereof, is or will be free from any claims of infringement and again, shall have no liability in relation to any such claims.

XMOS, XCORE, VocalFusion and the XMOS logo are registered trademarks of XMOS Ltd. in the United Kingdom and other countries and may not be used without written permission. Company and product names mentioned in this document are the trademarks or registered trademarks of their respective owners.

